

LIFTUSERGUIDE

Lyte Industries (Wales) Ltd

LYTE
LADDERS • TOWERS

LYTE INDUSTRIAL FOLDING TOWER

The maximum safe working load for the tower is 950kg.
This is to include the tower self weight and ballast.

All our user guides are compiled in order to give the user step by step instructions to ensure the product is assembled correctly and to the latest safety standard for use when working at height.

The law requires that anyone assembling and using a tower be competent to do so and should also have a copy of the correct manufacturer's instructions.

If you require further information on this please see the PASMA Operators Code of Practice or call us on **01792 796666**.

www.lyteladders.co.uk



PLEASE READ THIS SECTION CAREFULLY

The LIFT system is a lightweight scaffold tower and is used for indoor and outdoor use, due to the inherent collective fall protection measures.

The LIFT is manufactured, tested & certified to BSEN1004.

These instructions take into account the latest regulations, guidance and all product standards and is intended to give guidance on the best practice for the erection and dismantling of access towers. These instructions must always be used in conjunction with a suitable and sufficient Risk Assessment relative to the project.

Current regulations require that any person erecting towers must be competent and qualified to do so.

For full information on the correct erection and use of mobile access towers, consult the PASMA Operators Code of Practice (Revision 12.6).

Contact: PASMA at: Head Office & Administration Centre, PO Box 26969, Glasgow G3 9DR.

Safety Notes

This instruction guide aims to provide the user with step by step instructions to ensure the product is erected safely and correctly using the 3T method, Through The Trap. This method allows the operative to position himself through the trap of the platform and place horizontal braces ahead of him so that collective fall prevention measures are in place before he stands on the platform.

Before erection

1. Ensure that the instruction guide has been read and understood by anyone using the equipment. If in doubt contact your supplier.
2. Lyte Industries recommend two competent persons are used to build the range of Lyte Towers. On towers above 4mtrs it is an ESSENTIAL requirement that at least two persons are used.
3. Always ensure that the necessary components are available and inspected for damage and wear prior to erection. DAMAGED OR INCORRECT COMPONENTS SHALL NOT BE USED.
4. Ensure the ground is suitably firm and clear of obstruction.
5. All tower frames must be lifted on the outside of the tower but only in the effect base area of the stabilisers. It is acceptable to move frames with the aid of a rope, secured with a reliable knot.
6. The life of tower components will be increased if proper care is taken of them during handling, erection, transportation and storage. All components should be inspected after storage and transport.
7. Stabilisers shall always be fitted at the earliest opportunity.
8. Mobile access towers are not designed to be lifted or suspended.

Whilst erecting a tower

1. Outdoor freestanding towers must not exceed a platform height of 8.2m, for indoor use the maximum platform height is 12.2m. To ensure maximum stability is achieved, stabilisers or outriggers must always be fitted at the earliest opportunity, usually after the first module is complete. The quantity schedule overleaf illustrates the correct stabiliser units required for each platform height.
2. Always take into account the ground conditions i.e. are they capable of withstanding the loads imposed by the scaffolding.
3. Ensure the tower is level and vertical.
4. Ensure that the tower is not overloaded and that safe working loads are adhered to.
5. The Work at Height Regulations 2005 state that all platforms – from which a person is possible to fall a distance liable to cause personal injury – must be fitted with guardrails at a minimum height of 950mm above the platform itself. In addition to this, current regulations require intermediate guardrails be fitted to leave a gap no more than 470mm.
6. Toe boards are mandatory at all places of work from which it is possible that tools, equipment or other material may fall and is liable to cause personal injury. Their use on intermediate or rest platforms is not compulsory unless a risk assessment identifies a risk.

Whilst using the tower

1. Do not exceed the safe working load of the tower.
2. Ensure that castors are locked and that the Tower is both level and vertical.
3. All Lyte Industrial Towers must be climbed from the inside using the frames provided, **no other means of access is acceptable.**
4. Beware of high wind conditions; tie the tower to a rigid structure when working outdoors or in exposed conditions. Always refer to Beaufort Scale Force chart (shown inside).
5. If a tower is left unattended, it must be secured against unauthorised usage or adverse weather conditions.
6. Adjustable legs are intended only to level the tower and never to gain additional tower height.
7. For linking towers or special applications, always consult your supplier.
8. Care must be taken when using power tools, jet washers or other tools that impose side loads. The maximum side load on a freestanding tower is 20kgs.
9. It is not permissible to attach bridging between a tower and a building.
10. Never jump onto platforms.
11. Towers used outdoors shall, wherever possible, be secured to a building or other structure.

Before moving a tower

1. Towers should only be moved with the utmost caution. Before moving, ensure the route is clear of any obstructions, both at ground level and overhead (particularly overhead cables).
2. Never attempt to move a tower with people or materials still on it.
3. Ensure the tower height is reduced to 4m when stabilisers are in the correct position.
Reduce tower to 2m when stabilisers are in the incorrect position before moving.
4. Stabilisers should be left fitted in position, though raised no more than 25mm from the ground.
5. Move the tower only by applying manual effort, pushing at the base of the tower.
6. NEVER MOVE A TOWER IF WIND LEVELS ARE ABOVE 3 ON THE BEAUFORT SCALE.

After moving the tower

1. Always inspect the tower after moving and before use.
2. Always refer to the instructions in this guide.
3. Never throw equipment from the tower, either lower it with a rope or by hand.
4. Any components found to be damaged should be isolated, tagged and reported to someone in authority to either have them repaired or removed from service.
5. In accordance with current regulations any tower that has been erected must be checked every 7 days (minimum) to ensure that the tower continues to comply with the regulations.

The Beaufort Scale

Beaufort Scale	Description	Air Speed	Action
0	Calm, smoke rises easily	1mph	None required
<3	Leaves & small twigs in constant motion, wind extends light flag	12mph	No immediate action required
4	Moderate breeze, small branches move	17mph	Cease work
5	Strong breeze, large Branches bend	25mph	Tie tower to a rigid structure
>6	Walking progress impeded	40mph	Dismantle tower if such conditions are expected

Stabilisers

- Stabiliser should be fixed at the earliest opportunity.
- Fix stabilisers to each of the four corners at approx. 45° to the tower.
- Attach the clamp on the top boom to the frame upright leaving it hand tight so it can be adjusted later.
- Attach clamp on the bottom boom, then adjust both ensuring that the stabiliser is in the lowest position possible and feet are firmly in contact with the ground.
- When using telescopic stabilisers, extend the leg until contact with the ground is made then lock off by inserting the circlip.
- Adjust top and lower boom as necessary.
- When moving the tower, loosen the top clamp and lift 25mm then re-tighten. (see section on moving towers)
- After moving adjust all stabilisers ensuring firm contact is made with the ground and that the castors are locked.

Maximum Safe Working Loads

The maximum safe working load for the tower is 950kg.
This is to include the tower self weight and ballast.
The maximum capacity of each working level is 275kg, regardless of the number of decks.
The individual decks have a maximum capacity of 275kg.

Components for LIFT System		Weight	LIFT System	Weight
FDLC	125mm Locking Castor	1.20kg	0.6m System	45.75kg
ALU	Adjustable Leg	0.98kg	1.6m System	74.85kg
FTGF	4 Rung Frame	3.80kg	2.1m System	80.65kg
FTSF	6 Rung Frame	5.60kg	3.1m System	112.05kg
FTSF/8	8 Rung Frame	7.50kg	3.6m System	115.65kg
HD18	1.8 Hatch Deck	13.40kg	4.6m System	143.05kg
HB18	1.8m Horizontal Brace	2.05kg	5.1m System	148.85kg
DB21	2.1m Diagonal Brace	2.20kg	6.1m System	180.25kg
TBL18/ALU/SW	Aluminium Toe Board	6.40Kg		
SSU	Standard Stabiliser	3.80kg		
TSU	Telescopic Stabiliser	8.20kg		
FTBU	Folding Base Unit	15.00kg		

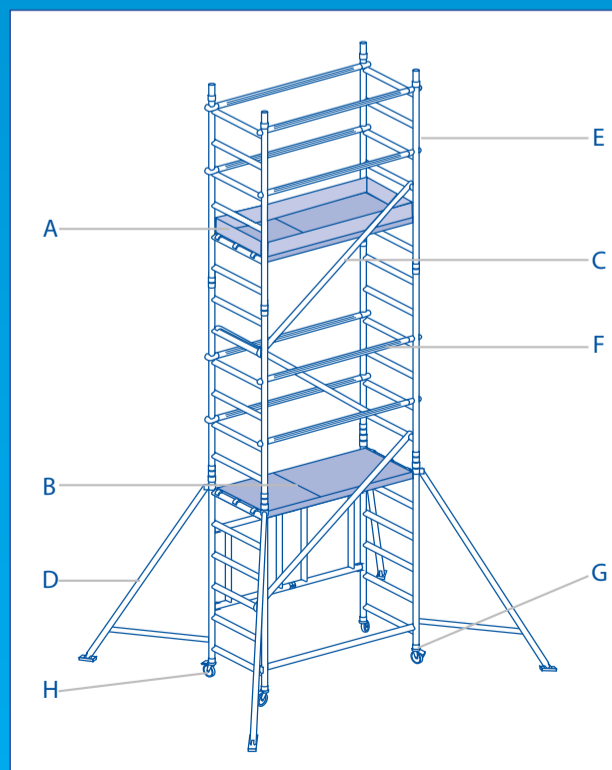

- A - Toe Board Set
- B - Hatch Deck
- C - Diagonal Brace
- D - Stabiliser
- E - 4, 6, 8 Rung Span Frame
- F - Horizontal Brace
- G - Adjustable Leg
- H - Castor

0.6m Platform Height

1. Open base unit and secure knuckle joints with pins. Ensure the base unit is squared
2. Fit horizontal brace at the front of the tower on the first rung as per drawing
3. Place the platform on the 2nd rung
4. Fit 3 horizontal braces, 1 at the front on the 4th rung and 2 at the front & back on the 6th rung



1.6m Platform Height

1. Open base unit and secure knuckle joints with pins. Ensure the base unit is squared
2. Fit horizontal brace at the front of the tower on the first rung as per drawing
3. Mount 2 x 4 rung frames on top of the base unit
4. Place platform on the 6th rung
5. Fit diagonal brace connecting at the 2nd rung to the 6th rung
6. Fit 4 x horizontal braces front and back on the 8th and 10th rungs
7. Fit toeboards on work platform



2.1m Platform Height

1. Open base unit and secure knuckle joints with pins. Ensure the base unit is squared
2. Fit horizontal brace at the front of the tower on the first rung as per drawing
3. Mount 2 x 6 rung frames on top of the base unit
4. Fit diagonal braces connecting at the 1st rung to the 5th and the 4th rung to the 8th
5. Place platform on the 8th rung
6. Fit the stabiliser ensuring the largest footprint is achieved
7. Using the 3t method place 4 x horizontal braces front and back the 10th & 12th rungs
8. Fit toeboards on work platform



3.1m Platform Height

1. Open base unit and secure knuckle joint with pin. Ensure the base unit is squared
2. Fit horizontal brace at the front of the tower on the first rung as per drawing
3. Place the platform on the 4th rung
4. Mount 2 x 4 rung frames on top of the base unit
5. Fit diagonal brace connecting at the 3rd rung to the 7th rung
6. Fit the stabiliser ensuring the largest footprint is achieved
7. Fit 4 horizontal braces front & back on the 6th rung and 8th rungs
8. Mount 2 x 6 rung frames on top of the existing frames
9. Fit diagonal brace connecting at the 7th rung to the 11th rung and the 8th to the 12th rung
10. Place platform on the 12th rung
11. Using the 3t method fit 4 horizontal braces front & back on the 14th rung and 16th rungs
12. Fit toeboards on work platform



3.6m Platform Height

1. Open base unit and secure knuckle joint with pin. Ensure base unit is squared
2. Fit horizontal brace at the front of the tower on the first rung as per drawing
3. Mount 2 x 6 rung frames on top of the base unit
4. Fit diagonal brace connecting at the 3rd rung to the 7th rung and the 7th rung to the 11th rung
5. Place platform on the 6th rung
6. Fit stabiliser ensuring that the largest footprint is achieved
7. Using the 3t method fit 4 x horizontal braces front & back on the 8th and 10th
8. Mount 2 x 6 rung frames on existing frames
9. Fit diagonal brace connecting the 10th to the 14th rung
10. Place platform on the 14th rung
11. Using the 3t method fit 4 x horizontal braces front & back on the 16th and 18th rungs
12. Fit toeboards on work platform



4.6m Platform Height

1. Open base unit and secure knuckle joints with pins. Ensure base unit is squared
2. Fit 1 x horizontal brace at the front of the tower on the first rung as per drawing
3. Mount 2 x 4 rung frames on top of the base unit
4. Place platform on the 2nd rung
5. Fit diagonal brace connecting at the 3rd rung to the 7th rung
6. Fit horizontal braces, 1 at the front on the 4th rung and 2 at the front & back on the 6th rung
7. Fit stabiliser ensuring that the largest footprint is achieved
8. Mount 2 x 6 rung frames on existing frames
9. Connect diagonal brace at the back of the tower from the 7th to the 11th rung
10. Place platform on the 10th rung
11. Using the 3t method fit 4 x horizontal braces front and back at the 12th and 14th rungs
12. Connect diagonal brace at the front of the tower from the 11th to the 15th rung
13. Mount 2 x 6 rung frames on existing frames
14. Connect diagonal brace at the back of the tower from the 14th to the 18th rung
15. Transfer the platform from the 2nd rung to the 18th rung
16. Transfer 3 x horizontal braces + 1 extra from the 4th & 6th rungs to the 20th and 22nd rungs front and back
17. Fit toe boards, the tower is now complete



*If you have any questions
or need help assembling
your tower please call us on
01792 796666*

LYTE

LADDERS • TOWERS

Tel: 01792 796666
www.lyteladders.co.uk
 Email: sales@lyteladders.co.uk

5.1m Platform Height

1. Open base unit and secure knuckle joints with pins. Ensure base unit is squared
2. Fit 1 x horizontal brace at the front of the tower on the first rung as per drawing
3. Mount 2 x 4 rung frames on top of the base unit
4. Place platform on the 4th rung
5. Fit diagonal brace connecting at the 3rd rung to the 7th rung
6. Fit 4 x horizontal braces at the on the 6th rung and the 8th rung front and back
7. Fit stabiliser ensuring that the largest footprint is achieved
8. Mount 2 x 8 rung frames on existing frames
9. Connect diagonal brace at the back of the tower from the 7th to the 11th rung
10. Connect diagonal brace at the back of the tower from the 11th to the 15th rung
11. Place platform on the 12th rung
12. Using the 3t method fit 4 x horizontal braces front and back at the 14th and 16th rungs
13. Mount 2 x 6 rung frames on existing frames
14. Connect diagonal brace at the back of the tower from the 15th to the 19th rung
15. Fit diagonal brace connecting from the 16th rung to the 20th rung
16. Transfer the platform from the 4th rung to the 20th rung
17. Transfer 4 x horizontal braces from the 6th & 8th rungs to the 22nd and 24th rungs; fit using the 3t method front and back
18. Fit toe boards, the tower is now complete



6.1m Platform Height

1. Open base unit and secure knuckle joints with pins. Ensure base unit is squared
2. Fit horizontal brace at the front of the tower on the first rung as per drawing
3. Mount 2 x 8 rung frames on top of the base unit
4. Fit diagonal brace connecting at the 3rd rung to the 7th rung
5. Fit diagonal brace connecting the 7th rung to the 11th rung
6. Place platform on the 8th rung
7. Fit stabiliser ensuring that the largest footprint is achieved
8. Using the 3t method fit 4 x horizontal braces front and back at the 10th and 12th rungs
9. Mount 2 x 8 rung frames on existing frames
10. Connect diagonal brace at the front of the tower connecting the 11th to the 15th rung
11. Fit diagonal brace the connecting the 15th rung to the 19th rung
12. Place platform on the 16th rung
13. Using the 3t method fit 4 x horizontal braces front and back at the 18th and 20th rungs
14. Mount 2 x 6 rung frames on existing frames
15. Connect diagonal brace at the front of the tower from the 19th to the 23rd rung
16. Connect diagonal brace at the back of the tower from the 20th to the 24th rung
17. Place platform on the 24th rung
18. Using the 3t method fit 4 x horizontal braces front and back at the 26th and 28th rungs
19. Fit toe boards, the tower is now complete

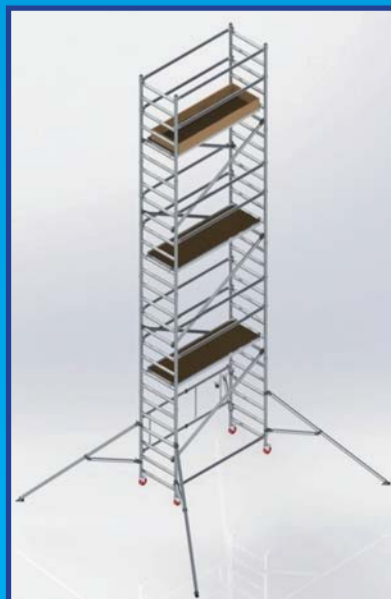

Platform Height (Max)	0.6m	1.6m	2.1m	3.1m	3.6m	4.6m	5.1m	6.1m
125mm Dual Locking Castors	4	4	4	4	4	4	4	4
Folding Tower Base Unit	1	1	1	1	1	1	1	1
1.0m Additional Frame	0	2	0	2	0	2	2	0
1.5m Additional Frame	0	0	2	2	4	4	2	2
2.0m Additional Frame	0	0	0	0	0	0	2	4
1.8m Additional Hatch Deck	1	1	1	2	2	2	2	3
1.8m Horizontal Brace	4	5	5	9	9	9	9	13
2.1m Diagonal Brace	0	1	2	3	3	4	5	6
1.8m Toe board Length	0	2	2	2	2	2	2	2
Toe board End Single Width	0	2	2	2	2	2	2	2
Standard Stabiliser Unit	0	0	4	4	4	0	0	0
Telescopic Stabiliser Unit	0	0	0	0	0	4	4	4