

Champion®

air



AIR COMPRESSOR

Model: CHAMP

Part No: 2225220 (110V) & 2225215 (230V)

OPERATING & MAINTENANCE INSTRUCTIONS

CE

GC0611

INTRODUCTION

Thank you for purchasing this CLARKE compressor.

Before attempting to operate the compressor, it is essential that you read this manual thoroughly and carefully follow all instructions given. In doing so you will ensure the safety of yourself and that of others around you, and you can also look forward to the compressor giving you long and satisfactory service.

GUARANTEE

This CLARKE product is guaranteed against faulty manufacture for a period of 12 months from the date of purchase. Please keep your receipt as proof of purchase.

This guarantee is invalid if the product is found to have been abused or tampered with in any way, or not used for the purpose for which it was intended.

Faulty goods should be returned to their place of purchase, no product can be returned to us without prior permission.

This guarantee does not effect your statutory rights.

ENVIRONMENTAL PROTECTION



Do not dispose of this product with general household waste. It must be disposed of according to the laws governing Waste Electrical and Electronic Equipment at a recognised disposal facility.

PARTS & SERVICE

For parts & Servicing, please contact your nearest dealer, or CLARKE International, on one of the following numbers.

PARTS & SERVICE TEL: 020 8988 7400

PARTS & SERVICE FAX: 020 8558 3622

or e-mail as follows:

PARTS: Parts@clarkeinternational.com

SERVICE: Service@clarkeinternational.com

CONTENTS

Introduction	2
Guarantee	2
Environmental Protection	2
Parts & Service	2
Accessories & Consumables	3
Table of Contents	3
Accessories & Consumables	3
General Safety Precautions	4
Electrical Connections	8
Safety Symbols	9
Overview	10
Preparation for Use	11
Operating Instructions	14
Maintenance	16
Troubleshooting	18
Technical Specification	19
Parts Lists and Diagrams	20
Declaration of Conformity	23

ACCESSORIES & CONSUMABLES

A wide range of airline accessories is available, including Filter/Regulators, Lubricators, High Pressure Hoses, Whip Hose etc. Contact your Clarke dealer for further information.

IMPORTANT: The use of parts other than genuine Clarke replacement parts may result in safety hazards, decreased tool performance, and will invalidate your warranty.

GENERAL SAFETY PRECAUTIONS

WORK AREA

1. **Keep the work area clean and well lit.** Floors should always be kept clear. Cluttered or dark areas invite accidents.
2. **Keep children and bystanders away while operating a power tool.** Distractions can cause loss of control.
3. The compressor should only be used in areas with adequate ventilation and should not be exposed to heat or used near flammable substances.

PERSONAL SAFETY

1. **ALWAYS** stay alert, watch what you are doing and use common sense when operating the compressor. Do not use the compressor while you are tired or under the influence of medication, drugs or alcohol. A moment of inattention can result in personal injury.
2. **ALWAYS** use eye protection when operating compressed air equipment, and ensure that others in the work area are protected from flying particles from the front and from the side.
3. **ALWAYS** protect yourself against electric shock. Never operate the compressor in wet or damp locations.
4. **NEVER** over-reach. Keep your proper footing and balance at all times to enable better control of the compressor in unexpected situations.
5. **NEVER** attempt any complex repairs yourself. If you have a technical problem contact your local Clarke dealer.
6. **ALWAYS** store the compressor out of reach of children.
7. **ALWAYS** protect your hearing. Ear protection should be worn when operating this compressor and it's associated air driven power tools.
8. **NEVER** direct the air stream at people or animals, as injury may result. Compressed air can cause soft tissue damage and propel dirt and other particles at high speed.
9. **NEVER** touch hot surfaces. During operation, the motor, connections, compressor body, cylinder head and tubes may get hot. Do not touch these until the compressor has cooled down.
10. **NEVER** insert your fingers or other objects inside the motor housing. Never operate the compressor without the cover in place.

GENERAL MACHINE USE AND CARE

1. Prior to use, all operators should become familiar with the instructions in this booklet. In particular, become familiar with the ON/OFF control for emergency stopping.

2. **ALWAYS** maintain the compressor with care and keep it clean for best / safest performance.
3. **NEVER** use this compressor if any part is damaged. Have it inspected and repaired by your Clarke dealer.
4. **NEVER** attempt to modify the compressor or its components in any way. Doing so will invalidate the guarantee and could result in personal injury.
5. **NEVER** abuse the power cable. Never pull on the cable when removing the plug from the socket or lift the compressor by the power cable.
6. **ONLY** use extension leads that are of an appropriate power rating and suitable for the work environment. Extension leads must have an earth connection. Inspect the extension lead regularly and replace if damaged.
7. **ONLY USE RECOMMENDED PARTS:** To avoid the risk of bursting, only hoses with a rated pressure of 10 bar, or more should be used. Never attempt to repair damaged hoses.
8. **NEVER** abuse the compressor by standing on it.

AIRLINE HOSES

1. **ALWAYS** ensure that equipment or power tools used in conjunction with the compressor have a safe working pressure exceeding that of the machine.
2. **ALWAYS** keep the air hose away from any attached power tools and ensure that the operator is not restricted by the length of the hose.
3. **ALWAYS** take care when a long air hose is required in the work area as it presents a trip hazard. Coil the hose away as soon as the job is finished.
4. **ALWAYS** avoid kinking or trapping the air hose. Always replace faulty hoses - never attempt a repair if a leak is detected.
5. **NEVER** abuse hoses or connectors. NEVER carry an air tool by the hose, or yank it to disconnect from the air supply. Keep hoses away from heat, oil and sharp edges. Check hoses for leaks or worn condition before use, and ensure that all connections are secure.
6. **ALWAYS** ensure the air supply is turned off at the machine outlet and any air pressure vented from within the compressor and any attached equipment when disconnecting air hoses or other equipment.

AIR COMPRESSOR SAFETY INSTRUCTIONS

- 1. ONLY USE WITHIN THE RECOMMENDED OPERATING TEMPERATURE RANGE:**
This compressor should only be used in an ambient temperature of between +5°C and +40°C (never at, or below freezing temperatures).
- 2. NEVER USE AN AIR COMPRESSOR WHICH APPEARS DEFECTIVE OR IS OPERATING ABNORMALLY:** If the compressor operates unusually or makes strange noises, switch off immediately and purge the air reservoir. Arrange repairs with your nearest Clarke dealer.
- 3. BREATHING QUALITY AIR:** This compressor should not be used to supply breathing quality air.
- 4. SAFETY VALVE:** Never remove or attempt to adjust the safety valve. The maximum pressure is factory set. Keep the safety valve free from paint and other accumulations.
- 5. AVOID UNINTENTIONAL STARTING:** Do not move the air compressor when it is connected to the mains power supply. When connecting the compressor to the power supply make sure the red button on top of the compressor control box is in the **OFF** (down) position.
- 6. BEFORE EACH USE CHECK THE COMPRESSOR AND HOSE FOR DAMAGED PARTS:** Never use the compressor if it has been damaged in any way. Have the compressor repaired by a qualified service engineer. Do not use the compressor if the On/Off switch does not operate correctly.
- 7. KEEP THE MOTOR AIR VENT CLEAR:** Keep the motor vents clear and free from dust. Wipe regularly to maintain an adequate supply of clean air to the compressor. Avoid using in dusty conditions.
- 8. OPERATE THE COMPRESSOR AT THE CORRECT VOLTAGE:** Make sure that the mains supply voltage is the same as the voltage shown on the label.
- 9. DRAIN AIR RESERVOIR:** Drain the air reservoir routinely. Switch off and slowly open the drain valve to release the air then tilt the compressor to empty any condensed water.
- 10. ALWAYS** adjust the pressure regulator to the recommended setting for the particular spray gun or air tool being used.
- 11. WHEN USING THE COMPRESSOR FOR PAINTING:**
 - Do not work in enclosed areas or near naked flames.
 - Ensure that the area in which you are working has good ventilation.
 - Protect your nose and mouth with a suitable face mask.
 - Always check the safety data sheets for substances being sprayed & ensure manufacturers instructions are followed.
- 12. DO NOT USE THIS COMPRESSOR TO INFLATE SMALL, LOW-PRESSURE OBJECTS:**
Items such as children's toys or footballs can explode if over-inflated.
- 13. NEVER STOP THE COMPRESSOR BY REMOVING THE PLUG OR SWITCHING OFF AT THE MAINS SUPPLY:** Always use the On/Off switch on the compressor.

SERVICING & STORAGE

1. **TURN OFF THE COMPRESSOR WHEN NOT IN USE:** When not in use, turn off by depressing the On/Off switch, then remove the plug from the mains supply. Slowly undo the drain valve to release the pressure from the reservoir. Close the drain valve before storage and ensure it is fully tightened before use.
2. **MOVING THE COMPRESSOR:** Always transport the compressor by lifting it by the handle.
3. **CLEANLINESS AND CONDITION OF THE COMPRESSOR:** Keep the external surfaces of the reservoir clean. Avoid impact damage and do not allow the reservoir to come into contact with abrasive or corrosive materials.
4. **DO NOT WIPE THE PLASTIC PARTS WITH SOLVENT:** Do not use solvents or thinners such as petrol, benzene, carbon tetrachloride or alcohol to clean the compressor, as these chemicals will damage the finish. With the compressor unplugged from the supply, use a dry cloth to wipe over the plastic casing.
5. **STORE THE COMPRESSOR PROPERLY:** When not in use the compressor should be stored in a secure, dry place, out of the reach of children. Always lock the storage area. DO NOT leave it exposed to the elements and avoid direct sunlight, direct heat, rain/moisture etc.
6. **ONLY USE PARTS AND ACCESSORIES RECOMMENDED IN THIS MANUAL:** The use of unauthorised accessories or attachments is not permitted and may result in personal injury or damage to the compressor. Do not attempt to repair or modify the compressor.

ELECTRICAL CONNECTIONS



WARNING! Read these electrical safety instructions thoroughly before connecting the product to the mains supply.

Before switching the machine on, ensure that the voltage of your electricity supply is the same as that indicated on the rating plate. Connecting to any other power source may cause damage.

- Model 2225220 requires an earthed 110Vac 50Hz power supply.
- Model 2225215 requires a domestic 230Vac 50Hz power supply.

This product may be fitted with a non-rewireable plug. If it is necessary to change the fuse in the plug, the fuse cover must be refitted. If the fuse cover becomes lost or damaged, the plug must not be used until a suitable replacement is obtained.

If the plug has to be changed because it is not suitable for your socket, or due to damage, it should be cut off and a replacement fitted, following the wiring instructions shown below. The old plug must be disposed of safely, as insertion into a mains socket could cause an electrical hazard.



WARNING! The wires in the power cable of this product are coloured in accordance with the following code:

Blue = Neutral Brown = Live Yellow and Green = Earth

If the colours of the wires in the power cable of this product do not correspond with the terminal markings of your plug, proceed as follows.

The wire which is coloured Blue must be connected to the terminal which is marked N or coloured Black.

- **The wire which is coloured Brown must be connected to the terminal which is marked L or coloured Red.**
- **The wire which is coloured Yellow and Green must be connected to the terminal which is marked E or \perp or coloured Green.**

Plug must be BS1363/A approved

Earth
(Green and Yellow)

Neutral
(Blue)

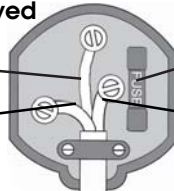

Always fit a 13 Amp fuse.

Live
(Brown)

Ensure that the outer sheath of the cable is firmly held by the clamp

We strongly recommend that this machine is connected to the mains supply via a Residual Current Device (RCD).

In the case of model 2225220, connect the mains lead to a suitable 110V (50Hz) electrical supply through an approved plug or suitably fused isolator switch. If using a portable 110V transformer, make sure it has a rated capacity sufficient to take the load of the compressor.

If in doubt, consult a qualified electrician. DO NOT attempt repairs yourself.

SAFETY SYMBOLS

The following safety symbols are present on the machine:



THIS COMPRESSOR SHOULD ALWAYS BE STARTED OR STOPPED BY MEANS OF THE START/STOP BUTTON LOCATED ON THE CONTROL BOX. THIS REDUCES THE RISK OF ACCIDENTAL START-UP.



THIS COMPRESSOR SHOULD NEVER BE STOPPED SUDDENLY BY UNPLUGGING FROM THE MAINS SUPPLY. THIS INCREASES THE RISK OF ACCIDENTAL START-UP. NEVER ABUSE THE POWER CABLE



RISK OF ELECTRIC SHOCK. THE COMPRESSOR MUST BE DISCONNECTED FROM THE MAINS SUPPLY BEFORE REMOVING ANY COVERS. DO NOT USE IN A DAMP ENVIRONMENT.



RISK OF ACCIDENTAL START-UP. THE COMPRESSOR COULD START AUTOMATICALLY IN THE EVENT OF A POWER CUT AND SUBSEQUENT RESET. DO NOT CARRY THE COMPRESSOR WHILE IT IS CONNECTED TO THE POWER SOURCE, OR WHEN THE TANK IS FILLED WITH COMPRESSED AIR.



THIS COMPRESSOR INCORPORATES SURFACES WHICH MAY REACH A HIGH TEMPERATURE DURING OPERATION. NEVER OPERATE WITH THE MOTOR COVER REMOVED.



96dB

THIS COMPRESSOR MAY PRODUCE A HIGH SOUND LEVEL DURING OPERATION. EAR PROTECTION SHOULD BE WORN.



READ THIS MANUAL BEFORE USE.

OVERVIEW

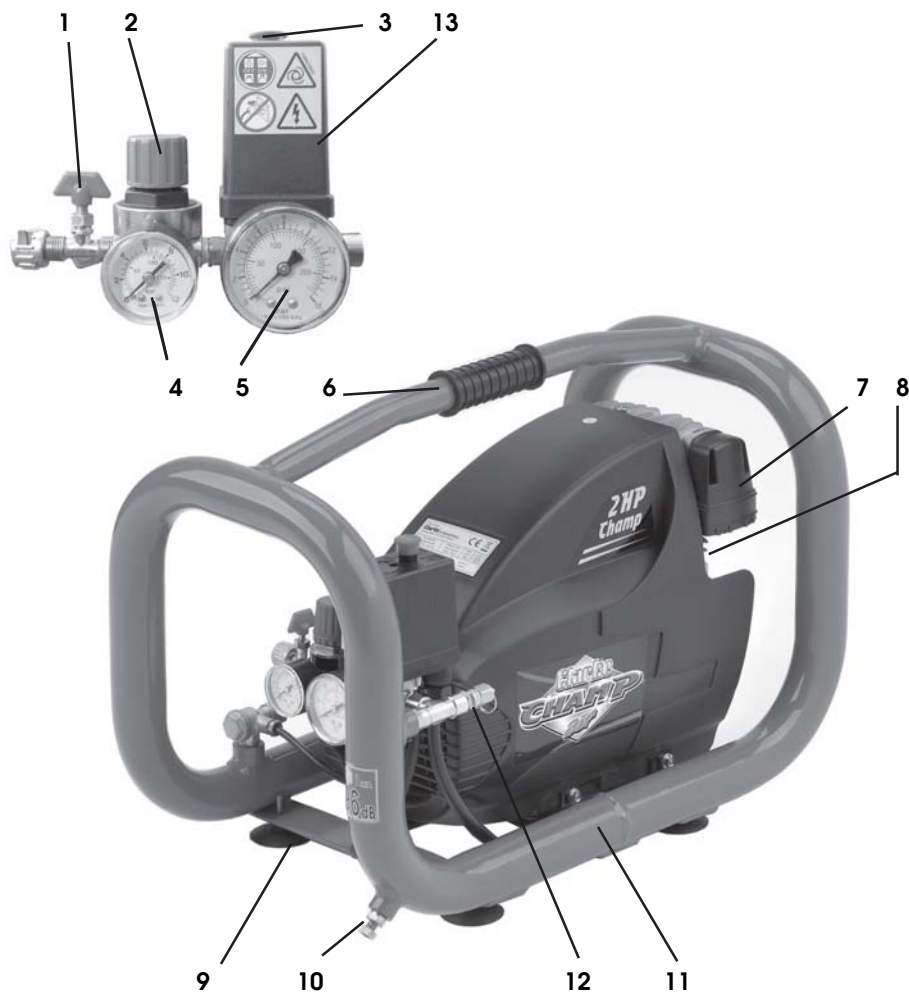

- | | | | |
|----|---------------------------|-----|--------------------------|
| 1 | Shut-off valve | 8. | Oil filler/dipstick |
| 2 | Output pressure regulator | 9. | Anti-vibration feet |
| 3. | ON/OFF switch | 10. | Drain valve |
| 4. | Delivery pressure gauge | 11. | Compressed air reservoir |
| 5. | Reservoir pressure gauge | 12. | Pressure safety valve |
| 6. | Handle | 13. | Pressure control switch |
| 7. | Air filter | | |

PREPARATION FOR USE



WARNING: Before using the compressor, make sure that you have read and understood the safety instructions.

UNPACKING

Take care when lifting the compressor from the packaging and get assistance if necessary to avoid personal injury or damage to the machine. Always lift using the handle and frame.

Caution! Never take the weight of the compressor by the regulator /pressure control switch. Get assistance if necessary.

After removing the compressor from its packaging, check that it has not been damaged in transit.

POSITIONING THE COMPRESSOR

This compressor should be positioned on a stable, flat surface.

Note: the compressor should not be operated on a steep slope or floor angle of greater than 15°.

If the compressor is placed on a shelf or raised off the ground, it should be secured appropriately to prevent it from falling off during use.

Do not cover the compressor. Always position it with good all-round air ventilation.

MOVING THE COMPRESSOR

When moving the compressor;

- Always use the handle.
- Do not lift by (or place a strain on) the air regulator fittings, hose or cables.
- Take care when moving the compressor to avoid damaging the valves or fittings.
- Always switch it off and disconnect it from the mains power supply.

CONNECTION AND START UP

Before connecting your compressor to the mains supply, check the following:-

- The supply voltage must be 110V (Champ 110 V - Part No; 2225220) or 230V (Champ 230 V - Part No; 2225215).
- The ON/OFF switch is in the OFF (depressed) position.

- The pressure regulator should be set at its lowest setting, i.e. turned fully anticlockwise. (- & + arrows are shown on the knob)
- If the compressor has not been used recently, open the drain valve shown in Fig 1 to drain any condensate which may have accumulated. When clear, close the valve, finger tight.

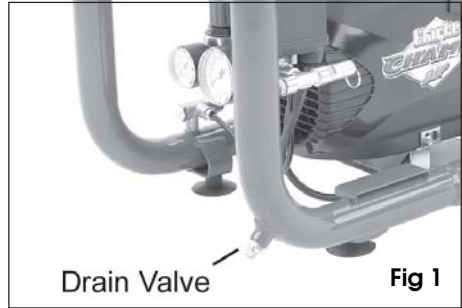

IMPORTANT: If the receiver is under pressure, keep your hands well away from the air being expelled. Remember, compressed air is DANGEROUS!



WARNING! BEFORE CONNECTING ANY AIR TOOL, MAKE SURE YOU HAVE READ AND FULLY UNDERSTOOD THE MANUFACTURER'S INSTRUCTION BOOKLET FOR THE AIR TOOL BEING USED. ALSO ENSURE THAT THE AIR TOOL IS COMPATIBLE WITH THE COMPRESSOR AND HOSE SPECIFICATIONS.

IF THE PRESSURE RATING OF THE TOOL IS LESS THAN 10 BAR, THE PRESSURE REGULATOR MUST BE USED TO ADJUST THE OUTPUT PRESSURE.

- 1 Connect a suitable air hose to the compressor outlet and the other end to the equipment to be used.
2. Attach the air hose to the air outlet using the hose nut as shown in Fig 2.
3. Ensure that the drain valve is closed finger tight as above.
4. Ensure the ON/OFF switch is in the OFF position, i.e. pushed down, then plug in the machine and switch ON at the mains supply.



CHECKING THE OIL

1. Remove dipstick as shown in Fig 3 and check the level of oil is between the MAX and MIN marks as shown in Fig 4. If not, top up to the correct level with Clarke SAE40 compressor oil available from your Clarke dealer.
2. After the first 5 working hours, replace the oil as described under MAINTENANCE on page 16.



Fig 3

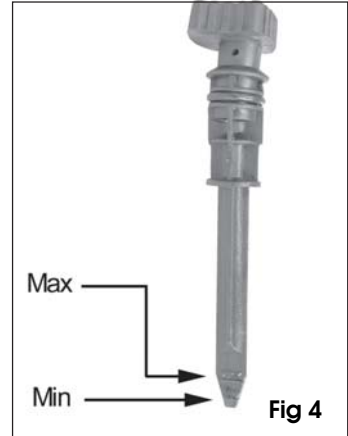
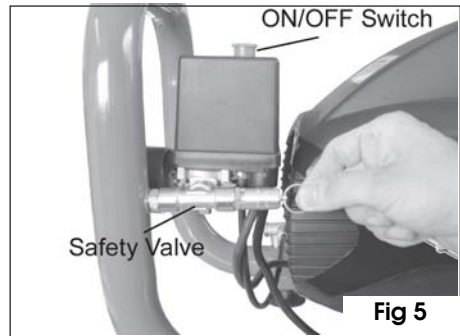

Fig 4

OPERATING INSTRUCTIONS

STARTING THE COMPRESSOR

1. Pull the ON/OFF switch shown in Fig 5, upwards to start the compressor. The motor should start immediately and run while the reservoir is being pressurised.
2. When starting the compressor for the first time and before connecting it to the airline equipment, leave it running for about 10 minutes to permit a good distribution of lubricating oil.
3. Check the operation of the safety valve under pressure on a daily basis by pulling the ring shown in Fig 5. Air should be released while the ring is pulled and stop when the ring is released.
 - If the valve does not operate as described, or is stuck, it must be replaced by your Clarke dealer before the compressor is used.



WARNING: Never remove or attempt to adjust the safety valve.

- Observe that the compressor stops automatically when the maximum pressure of 10 bar is reached. The pressure is indicated on the reservoir pressure gauge shown in Fig 6.

WORKING PRESSURE ADJUSTMENT

Different air tools which can be powered by the compressor will require different operating pressures to work efficiently.

1. Adjust the air pressure delivered using the pressure regulator.
2. Turn the pressure regulator knob clockwise to increase pressure & anti-clockwise to decrease it.
 - The pressure setting will be displayed by the outlet pressure gauge shown in Fig 6.
3. Use the regulator locking ring to set the pressure.

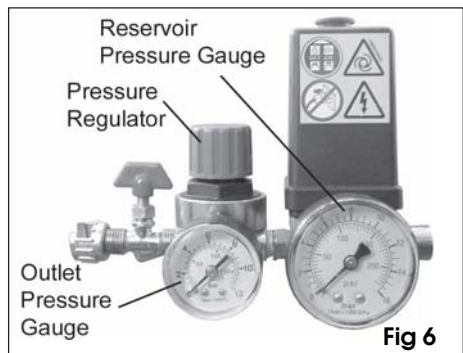

NORMAL RUNNING

The compressor is fitted with a combined ON/OFF pressure control switch whose cut-in and cut-out pressures are factory set.

When the reservoir pressure falls below the minimum threshold setting, (about 2-bar lower than the maximum pressure) the compressor will re-start and will cut out when the maximum reservoir pressure is achieved.

Note: If the machine pumps continuously without intermittently switching on and off, the compressor is too small for the demand of the application/tool being used and damage could result. Consult your Clarke dealer.

OVERLOAD CUT-OUT

The compressor is fitted with an overload cutout to protect the motor in the event of overheating.

If the device should trip out and shut down the compressor, wait around 5 minutes for the machine to cool down before re-setting the device by pressing the overload reset button shown in Fig 7.

If, having re-started the compressor, the overload cutout trips again, set the main switch to the OFF position, unplug the machine and consult your Clarke dealer.

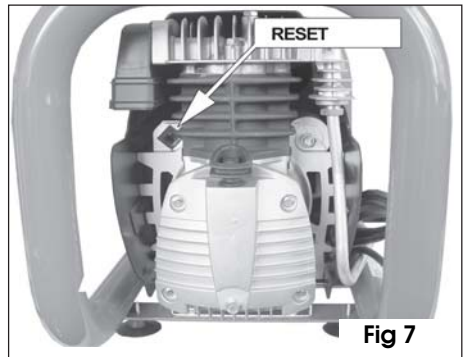

Fig 7

SHUTTING DOWN AND STORAGE

Press the red ON/OFF switch to shut off the compressor.

Never stop the compressor by unplugging it from the power supply. It should be turned off as above.

After use, set the outlet pressure back to zero.

Trigger all equipment (tools, spraygun etc) to release any air pressure from the air hose before disconnecting the hose from the compressor.

Before transporting or storing the compressor, release all air pressure from the reservoir by opening the drain valve shown in Fig 1.

- It may be desirable to place a container beneath the compressor to catch any condensate.

Avoid storing the compressor in an environment where the temperature is likely to drop to or below freezing.

MAINTENANCE



WARNING: Always vent the air receiver before carrying out any adjustments, servicing or maintenance. Never unscrew a connection whilst the air receiver is under pressure. Always ensure the receiver has been vented.

DAILY / WEEKLY / BEFORE USE

1. Drain any condensate by opening the drain valve fitted to the receiver. As soon as air starts to flow out, close the drain cock.
2. Inspect the compressor for damaged parts or for any loose screws or bolts.
3. Check the oil level is between the MAX & MIN marks on the dipstick & top up if necessary. (Use Clarke SAE40 compressor oil). Ensure the oil does not drop below the minimum level to avoid damage to the machine.

PERIODICALLY

1. Check and clean, if necessary, the sponge air inlet filter element shown in Fig 8. The filter may be removed from the plastic cover and gently washed in warm soapy water. Rinse and allow to dry thoroughly before re-fitting.

This should be done more frequently if the compressor operates in a very dusty area.)



Fig 8



CAUTION: NEVER OPERATE THE COMPRESSOR WITHOUT THE SPONGE FILTER FITTED, AS FOREIGN MATTER COULD SERIOUSLY DAMAGE THE INTERNAL COMPONENTS. IF DAMAGED, THE FILTER SHOULD BE REPLACED.

2. Keep the cooling fins clear of dust if the machine is being used in a dirty workplace.

6 MONTHLY/500 HOURS

If the oil has become contaminated it should be replaced as follows:

1. Remove the dipstick and unscrew the drain plug from the crankcase cover as shown in Fig 9 and drain the oil into a container.

Note: This operation is best performed when the machine is warm so as to encourage the oil to drain easily.

2. Replace the drain plug and re-fill with fresh oil up to the MAX level on the dipstick using Clarke SAE40 compressor oil.



CAUTION: PROLONGED EXPOSURE TO USED OIL IS DANGEROUS, ALWAYS WASH YOUR HANDS THOROUGHLY AFTER HANDLING USED OIL.



Fig 9

RECOMMENDED OILS

Any compressor oil can be used which is suitable for use at room temperatures from +5°C to +40°C.

Clarke SAE40 Compressor Oil (1 litre) is available from your Clarke dealer (part no 3050810). See the Clarke catalogue for other consumables.

ENVIRONMENTAL PROTECTION

One of the most damaging sources of environmental pollution is oil. Do not throw away used oil with domestic refuse or flush down a sink or drain. Collect old oil in a leakproof container and take it to your local waste disposal site.

EVERY 2 YEARS

Check the non-return valve shown in Fig 10, and if necessary, replace the gasket (O-ring) in Fig 11.

IMPORTANT: *The use of parts other than Clarke replacement parts may result in safety hazards, decreased tool performance and will invalidate your warranty.*

Your Clarke compressor has been designed to give long and trouble free service. If, however, having followed the instructions in this booklet carefully, you encounter problems, take the unit to your local Clarke dealer.

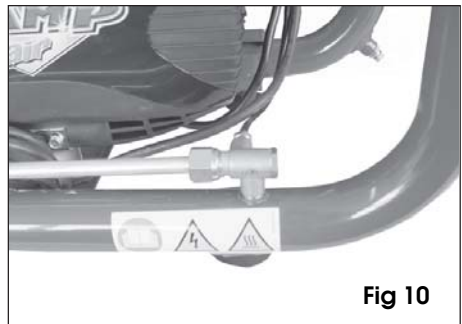

Fig 10

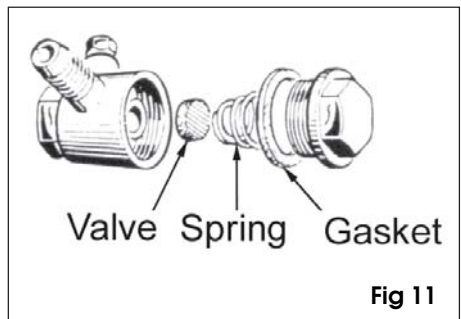

Fig 11

TROUBLESHOOTING

SYMPTOM	PROBLEM	SOLUTION
Pressure drop in the receiver.	Air leaks at connections.	Run the compressor to create maximum pressure. Switch it off and brush a soapy water solution onto all connections. Look carefully for air bubbles being forced out. Tighten any connections where bubbles are seen. If problem persists, contact your Clarke dealer.
Compressor stops and will not start again.	Bad electrical connections. Blown fuse. Overload cut-out switch has tripped.	Check connections. Clean and tighten as necessary. Renew/replace fuse. Switch off machine and wait 5 minutes before pressing reset button.
Compressor fails to reach the set pressure and overheats easily.	Compressor head gasket failed or valve damaged.	Stop the compressor and contact your Clarke dealer.
Compressor does not start.	Air reservoir already charged.	Open drain cock to expel air. Compressor should start again when the stored reservoir pressure trips the pressure control switch (at approx 95 psi).
Air found leaking from the pressure switch valve when the compressor is not running.	Faulty non-return valve.	Vent the receiver completely of air. Remove the valve end plug, carefully clean the valve end seat and gasket, then re-assemble. See Fig 11.
Pressure switch valve leaks after the compressor has been running for more than about a minute.	Failure of the empty-start valve in pressure control switch.	Replace the pressure control switch.
Air pressure cannot be adjusted at the regulator.	Broken diaphragm inside the regulator body.	Replace regulator.
Compressor keeps running after the maximum pressure has been reached, causing the safety valve to activate.	Incorrect operation of the pressure control switch.	Contact your Clarke dealer.
Compressor making undue mechanical noise.	Compressor is damaged and needs overhaul.	Stop the compressor and contact your Clarke dealer.
Compressor will not run.	Motor winding burnt out.	Contact your Clarke dealer.

In the event that any of the above situations arise, requiring the dismantling and overhaul of the compressor, contact your Clarke International Service Department on 020-8988-7400.

SPECIFICATION

Part No	2225220	2225215
Weight	23.2 kg	23.2 kg
Dimensions (L x W x H) mm	540 x 300 x 388	540 x 300 x 388
Power Supply	110v@50Hz	230v@50Hz
Fuse Rating	13 amps	13 amps
Air Receiver Capacity	2.4 litres	2.4 litres
Duty Cycle	S1 (continuous)	S1 (continuous)
Max Air Pressure	10 Bar / 145 psi	10 Bar / 145 psi
Max Flow Rate	217L/Min (7.6 cu.ft/min)	217L/Min (7.6 cu.ft/min)
Operating Temperature	+5°+40°C	+5°+40°C
Sound Power Level	95 dB LwA	95 dB LwA
Guaranteed Sound Power Level	96 dB LwA	96 dB LwA

Please note that the details and specifications contained herein, are correct at the time of going to print. However, Clarke International reserve the right to change specifications at any time without prior notice.

PARTS DIAGRAM - COMPRESSOR

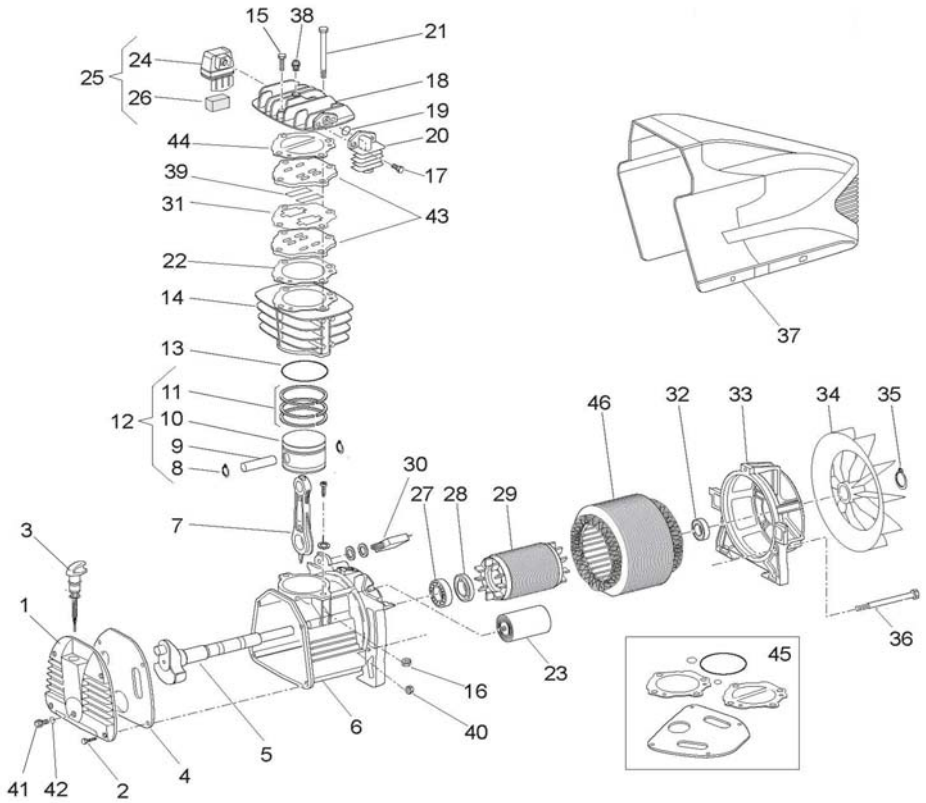

PARTS LIST - COMPRESSOR

No	Description	Part No	Qty
1	END COVER	FN116CN0025	1
2	BOLT	FN014006024	4
3	OIL PLUG/DIPSTICK	FN012089000	1
4	CRANKCASE GASKET	FN116120016	1
5	CRANKSHAFT	FN116CN0017	1
6	CRANKCASE	FN116120006	1
7	CONNECTING ROD	FN116121005	1
8	CIRCLIP	FN015001000	1
9	GUDGEON PIN	FN116022040	1
10	PISTON	FN116022004	1
11	PISTON RINGS (SET)	FN216022002	1
12	PISTON ASSEMBLY	FN416022004	1
13	O-RING	FN010133000	1
14	CYLINDER BODY	FN116CN0015	1
15	SCREW	FN014013031	2
16	NUT	FN014003001	2
17	SCREW	FN014013021	2
18	CYLINDER HEAD	FN116CN0013	1
19	O-RING	FN010130000	1
20	MANIFOLD	FN016NC1004	2
21	BOLT	FN014001075	2
22	CYL. GASKET (230V) CYL. GASKET (110V)	FN116HT0002 FN116NC0006	1 1
23	CONDENSER (230V) CONDENSER (110V)	FN009200015 FN009200035	1 1

No	Description	Part No	Qty
24	AIR FILTER HOUSING	FN017082002	1
25	INLET FILTER ASSY	FN317082000	1
26	FILTER ELEMENT	FN017082001	1
27	BEARING	FN033082000	1
28	SEALING RING	FN010132000	1
29	MOTOR ROTOR	FN116093005	1
30	OVERLOAD CUTOUT	FN008055000	1
31	VALVE GASKET	FN116CN0051	1
32	BEARING	FN033005000	1
33	REAR COVER	FN116120007	1
34	FAN	FN116120008	1
35	CIRCLIP	FN015083000	1
36	LONG BOLT	FN014002128	3
37	HOUSING	FN116NC0003	1
38	SAFETY VALVE	FN011000183	1
39	VALVE BLADE	FN116022038	2
40	NUT	FN1611900100	3
41	SCREW	FN014013024	1
42	O-RING	FN010072000	1
43	VALVE PLATE	FN116CN0030	2
44	HEAD GASKET(110V) HEAD GASKET(230V)	FN116120014 FN116CN0050	1 1
45	GASKET SET (110V) GASKET SET (230V)	FN216CN0002 FN216CN0001	1 1
46	STATOR (230V) STATOR (110V)	FN316CN1605 FN316CN1601	1 1

PARTS LIST - PNEUMATICS

No	Description	Part No	Qty
47	FOOT	FN020186000	4
48	DRAIN PLUG	FN022082000	1
49	BASE PLATE	FN104HB0001	1
50	HANDLE	FN116022015	1
51	DELIVERY TUBE	FN104CN0002	1
52	OLIVE	FN161535012	1
53	LOCK NUT	FN116HP0011	1
54	SPRING	FN47159001	1
55	O-RING	FN10113000	1
56	SEAL	FN47159002	1
57	PRESSURE GAUGE 0-300psi	FN330007000	1
58	PRESSURE GAUGE 0-180psi	FN330006000	1

No	Description	Part No	Qty
59	T - FITTING	FN11177000	1
60	SAFETY VALVE	FN047206000	1
61	CONNECTOR	FN11017000	2
62	PLUG	FN111001000	1
63	SHUT-OFF VALVE	FN322007000	1
64	CONNECTING TUBE	FN46001000	1
65	PRESSURE SWITCH	FN321028000	1
66	NON-RETURN VALVE	FN347072000	1
67	AIR RECEIVER	FN104HN0001	1
68	PRESSURE REDUCER	FN319117000	1
69	POWER CABLE (110V) POWER CABLE (230V)	FN172P05200 FN101GA0200	1 1

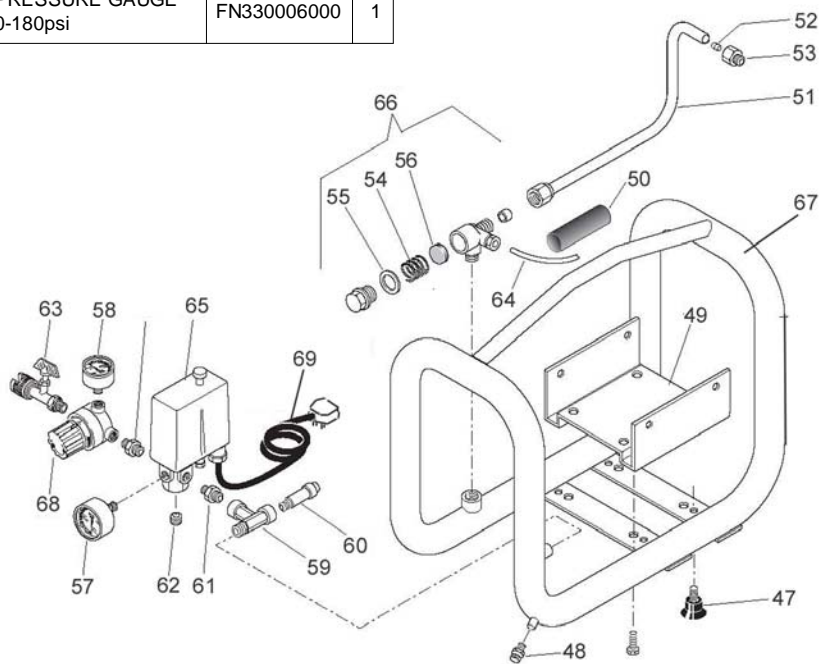

DECLARATION OF CONFORMITY



Clarke[®]
INTERNATIONAL

Hemnal Street, Epping, Essex CM16 4LG

DECLARATION OF CONFORMITY

This is an important document and should be retained.

We hereby declare that this product(s) complies with the following directive(s):

2004/108/EC *Electromagnetic Compatibility Directive.*

2006/42/EC *Machinery Directive.*

2006/95/EC *Low Voltage Equipment Directive.*

The following standards have been applied to the product(s):

EN 60335-1:2002, EN 1012-1:1997, EN 60204-1:2006+A1:2009, EN 61000-6-2:2006,
EN 61000-6-3:2007.

The technical documentation required to demonstrate that the product(s) meet(s) the requirement(s) of the aforementioned directive(s) has been compiled and is available for inspection by the relevant enforcement authorities.

The CE mark was first applied in: 2009

Product Description:	Compressors
Model number(s):	Pioneer 230V /110V
Serial / batch Number:	2225220 / 2225221
Date of Issue:	01/08/2011

Signed:

J.A. Clarke
Director

A SELECTION FROM THE VAST RANGE OF

Clarke®

QUALITY PRODUCTS

AIR COMPRESSORS

From DIY to industrial. Plus air tools, spray guns and accessories.

GENERATORS

Prime duty or emergency standby for business, home and leisure.

POWER WASHERS

Hot and cold, electric and engine driven - we have what you need

WELDERS

Mig, Arc, Tig and Spot. From DIY to auto/industrial.

METALWORKING

Drills, grinders and saws for DIY and professional use.

WOODWORKING

Saws, sanders, lathes, mortisers and dust extraction.

HYDRAULICS

Cranes, body repair kits, transmission jacks for all types of workshop use.

WATER PUMPS

Submersible, electric and engine driven for DIY, agriculture and industry.

POWER TOOLS

Angle grinders, cordless drill sets, saws and sanders.

STARTERS/CHARGERS

All sizes for car and commercial use.

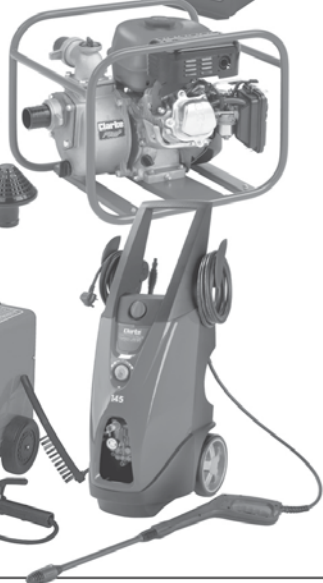

PARTS & SERVICE: 0208 988 7400

E-mail: Parts@clarkeinternational.com or Service@clarkeinternational.com

SALES: UK 01992 565333 or Export 00 44 (0)1992 565335

Clarke INTERNATIONAL Hemnall Street, Epping, Essex CM16 4LG
www.clarkeinternational.com