

# Genie®



## Operator's Manual

*with Maintenance Information*

First Edition  
Seventh Printing  
Part No. 52421

**Z™-45/25**

**Z™-45/25J**

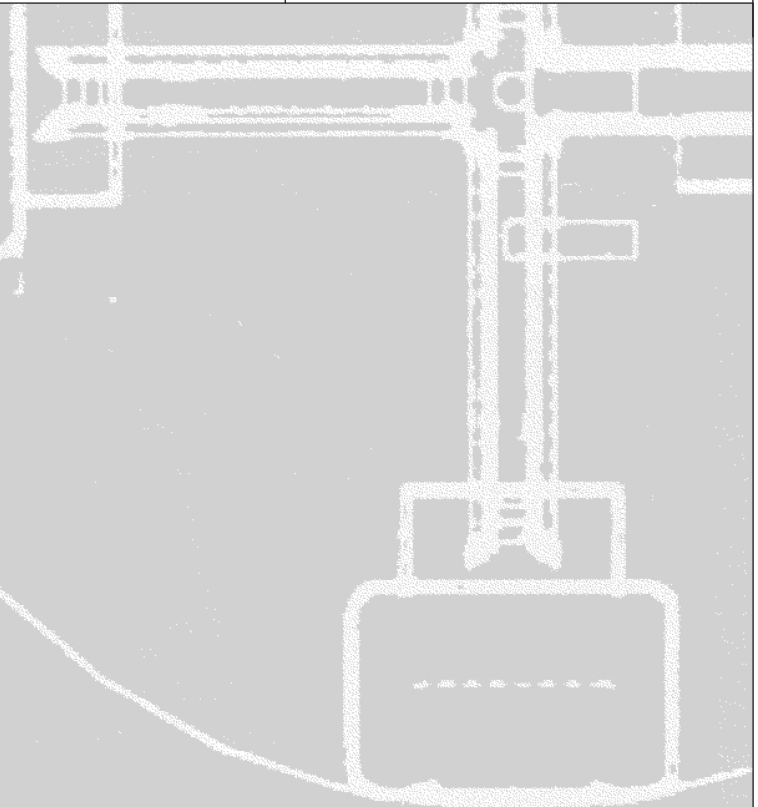

---

## Important

Read, understand and obey these safety rules and operating instructions before operating this machine. Only trained and authorized personnel shall be permitted to operate this machine. This manual should be considered a permanent part of your machine and should remain with the machine at all times. If you have any questions, call Genie Industries.

---

## Contents

	Page
Safety .....	1
Controls .....	7
Pre-operation Inspection .....	10
Maintenance .....	12
Function Tests .....	16
Workplace Inspection .....	23
Operating Instructions .....	24
Transport Instructions .....	29
Decals .....	30
Specifications .....	32

---

## Contact us:

Internet: <http://www.genielift.com>  
E-mail: [techpub@genieind.com](mailto:techpub@genieind.com)

---

Copyright © 1998 by Genie Industries

First Edition: Seventh Printing, May 2002

"Genie" and "Z" are registered trademarks of Genie Industries in the U.S.A. and many other countries.

These machines comply with ANSI/SIA 92.5-1992.

 Printed on recycled paper

Printed in U.S.A.

---

# Safety Rules



---

## Danger

Failure to obey the instructions and safety rules in this manual will result in death or serious injury.

---

## Do Not Operate Unless:

- You learn and practice the principles of safe machine operation contained in this operator's manual.

### 1 Avoid hazardous situations.

**Know and understand the safety rules before going on to the next section.**

2 Always perform a pre-operation inspection.

3 Always perform function tests prior to use.

4 Inspect the workplace.

5 Only use the machine as it was intended.

- You read, understand and obey:

Manufacturer's instructions and safety rules—safety and operator's manuals and machine decals

employer's safety rules and worksite regulations

applicable governmental regulations

- You** are properly trained to safely operate the machine.

SAFETY RULES

### Electrocution Hazards

This machine is **not** electrically insulated and will **not** provide protection from contact with or proximity to electrical current.

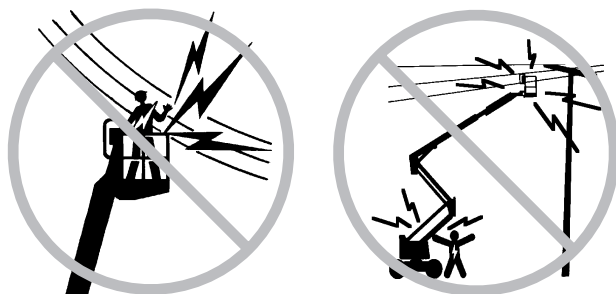

Maintain safe distances from electrical power lines and apparatus in accordance with applicable governmental regulations and the following chart.

Voltage Phase to Phase	Minimum Safe Approach Distance	
	Feet	Meters
0 to 300V	Avoid Contact	
300V to 50KV	10	3.1
50KV to 200KV	15	4.6
200KV to 350KV	20	6.1
350KV to 500KV	25	7.6
500KV to 750KV	35	10.7
750KV to 1000KV	45	13.7

Allow for platform movement, electrical line sway or sag and beware of strong or gusty winds.

Keep away from the machine if it contacts energized power lines. Personnel on the ground or in the platform must not touch or operate the machine until energized power lines are shut off.

Do not use the machine as a ground for welding.

### Tip-over Hazards

Occupants and equipment shall not exceed the maximum platform capacity.

<b>Maximum platform capacity</b>	500 lbs	227 kg
<b>Maximum occupants</b>	2	

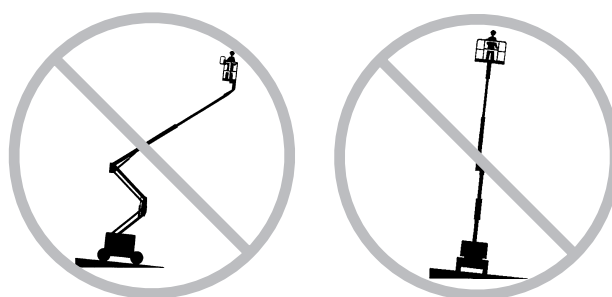

Do not raise or extend the boom unless the machine is on a firm, level surface.

Do not depend on the tilt alarm as a level indicator. The tilt alarm sounds in the platform only when the machine is on a severe slope.

If the tilt alarm sounds:  
Do not extend, rotate or raise the boom above horizontal. Move the machine to a firm, level surface before raising the platform. If the tilt alarm sounds when the platform is raised, use extreme caution to retract the boom and lower the platform. Do not rotate the boom while lowering. Move the machine to a firm, level surface before raising the platform.

Do not use the platform controls to free a platform that is caught, snagged or otherwise prevented from normal motion by an adjacent structure. All personnel must be removed from the platform before attempting to free the platform using the ground controls.

Do not alter or disable the limit switch(es).

**SAFETY RULES**

Do not operate the machine in strong or gusty winds. Do not increase the surface area of the platform or the load. Increasing the area exposed to the wind will decrease machine stability.



Use extreme care and slow speeds while driving the machine in stowed position across uneven terrain, debris, unstable or slippery surfaces and near holes and drop-offs.

Do not drive the machine on or near uneven terrain, unstable surfaces or other hazardous conditions with the boom raised or extended.

Do not push off or pull toward any object outside of the platform.

<b>Maximum allowable side force - ANSI &amp; CSA</b>	150 lbs 667 N
--	------------------

<b>Maximum allowable side force - CE</b>	90 lbs 400 N
--	-----------------

Do not modify or alter an aerial work platform. Mounting attachments for holding tools or other materials onto the platform, toeboards or guard rail system can increase the weight in the platform and the surface area of the platform or the load.

Do not place or attach overhanging loads to any part of this machine.

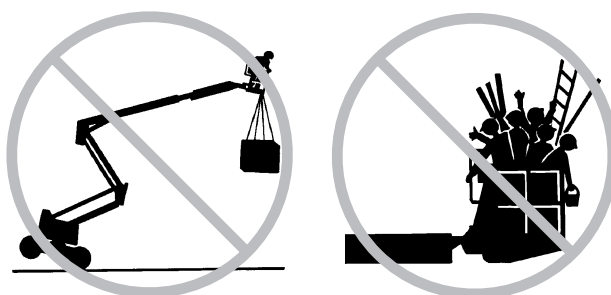

Do not place ladders or scaffolds in the platform or against any part of this machine.

Do not use the machine on a moving or mobile surface or vehicle.

Be sure all tires are in good condition, air-filled tires are properly inflated and lug nuts are properly tightened.

**Z-45/25 & Z-45/25J Narrow Base Models:** Do not use air-filled tires. These machines are equipped with foam-filled tires. Wheel weight and proper counterweight configuration are critical to stability.

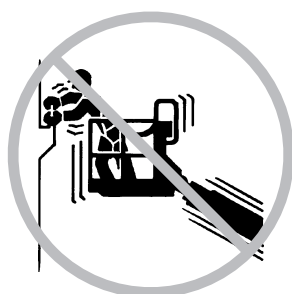

Do not alter or disable machine components that in any way affect safety and stability.

Do not replace items critical to machine stability with items of different weight or specification.

**SAFETY RULES**

- Do not use the machine as a crane.
- Do not push the machine or other objects with the boom.
- Do not contact adjacent structures with the boom.
- Do not tie the boom or platform to adjacent structures.
- Do not place loads outside the platform perimeter.

**Fall Hazards**



Occupants must wear a safety belt or harness in accordance with governmental regulations. Attach the lanyard to the anchor provided in the platform.

It is recommended that operators wear an approved hard hat when operating the machine.

Do not sit, stand or climb on the platform guard rails. Maintain a firm footing on the platform floor at all times.

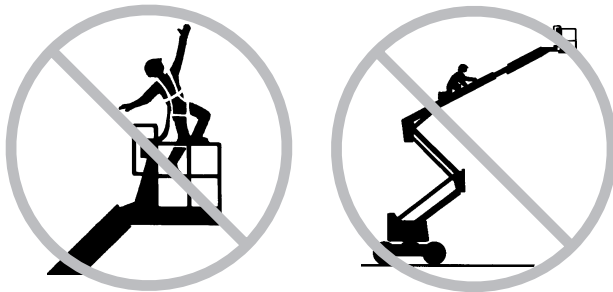

- Do not climb down from the platform when raised.
- Keep the platform floor clear of debris.
- Lower the platform entry mid-rail or close the entry gate before operating.

**Bodily Injury Hazard**

Do not operate the machine with a hydraulic oil or air leak. An air leak or hydraulic leak can penetrate and/or burn skin.

Always operate the machine in a well-ventilated area to avoid carbon monoxide poisoning.

**Collision Hazards**



Be aware of limited sight distance and blind spots when driving or operating.

Be aware of boom position when rotating the turntable.

Check the work area for overhead obstructions or other possible hazards.

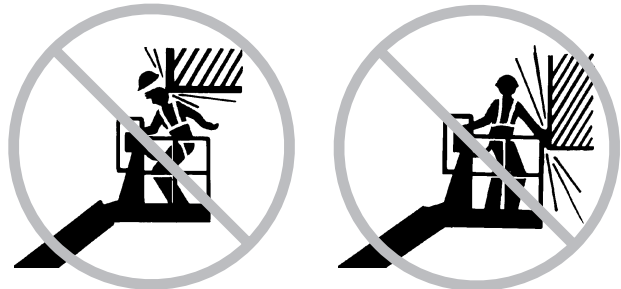

Be aware of crushing hazard when grasping the platform guard rail.

Observe and use color-coded direction arrows on the platform controls and drive chassis for drive and steer functions.

## SAFETY RULES

Do not lower the boom unless the area below is clear of personnel and obstructions.



Limit travel speed according to condition of ground surface, congestion, slope, location of personnel, and any other factors which may cause collision.

Do not operate a boom in the path of any crane unless the controls of the crane have been locked out and/or precautions have been taken to prevent any potential collision.

No stunt driving or horseplay while operating a machine.

## Explosion and Fire Hazards

Do not start the engine if you smell or detect liquid petroleum gas (LPG), gasoline, diesel fuel or other explosive substances.

Do not refuel the machine with the engine running.

Refuel the machine and charge the battery only in an open, well-ventilated area away from sparks, flames and lighted tobacco.

Do not operate the machine in hazardous locations or locations where potentially flammable or explosive gases or particles may be present.

## Damaged Machine Hazards

Do not use a damaged or malfunctioning machine.

Conduct a thorough pre-operation inspection of the machine and test all functions before each work shift. Immediately tag and remove from service a damaged or malfunctioning machine.

Be sure all maintenance has been performed as specified in this manual and the *Genie Z-45/25 & Genie Z-45/25J Service Manual*.

Be sure all decals are in place and legible.

Be sure operator's, safety and responsibilities manuals are complete, legible and in the storage container located on the platform.

## Battery Safety

### Burn Hazards

Batteries contain acid. Always wear protective clothing and eyewear when working with batteries.

Avoid spilling or contacting battery acid. Neutralize battery acid spills with baking soda and water.

### Explosion Hazard

Keep sparks, flames and lighted tobacco away from batteries. Batteries emit explosive gas.

### Electrocution Hazard

Avoid contact with electrical terminals.

### Component Damage Hazards

Do not use any battery or charger greater than 12V to jump-start the engine.

Do not use the machine as a ground for welding.

Be sure the hydraulic shutoff valves (located by hydraulic tank) are open before starting the engine.

## SAFETY RULES

## Decal Legend

Genie product decals use symbols, color coding and signal words to identify the following:



Safety alert symbol—used to alert personnel to potential personal injury hazards. Obey all safety messages that follow this symbol to avoid possible injury or death.

**▲ DANGER**

Red—used to indicate the presence of an imminently hazardous situation which, if not avoided, will result in death or serious injury.

**▲ WARNING**

Orange—used to indicate the presence of a potentially hazardous situation which, if not avoided, could result in death or serious injury.

**▲ CAUTION**

Yellow with safety alert symbol—used to indicate the presence of a potentially hazardous situation which, if not avoided, may cause minor or moderate injury.

**CAUTION**

Yellow without safety alert symbol—used to indicate the presence of a potentially hazardous situation which, if not avoided, may result in property damage.

**NOTICE**

Green—used to indicate operation or maintenance information.



# Controls

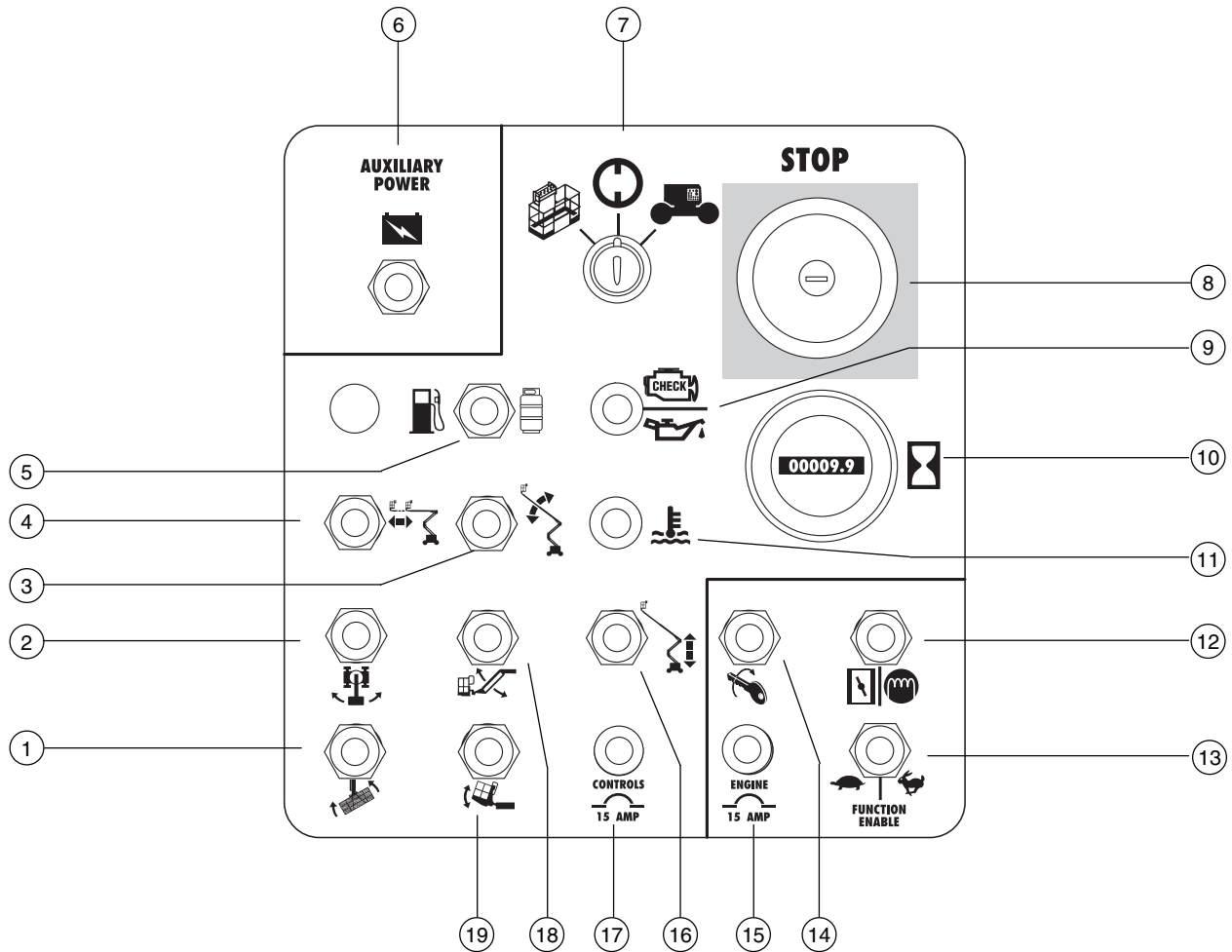

## Ground Control Panel

- |  |  |
|--|--|
| 1 Platform rotate switch   | 11 Diesel models: Water temperature light  |
| 2 Turntable rotate switch  | 12 Gasoline/LPG models: Choke switch<br>Diesel models: Glow plug switch (option) |
| 3 Primary boom up/down switch  | 13 Function enable switch  |
| 4 Primary boom extend/retract switch   | 14 Engine start switch   |
| 5 Gasoline/LPG models: Fuel select switch                                      | 15 15A breaker for engine electrical circuits                                    |
| 6 Auxiliary power switch   | 16 Secondary boom up/down switch   |
| 7 Key switch for platform/off/ground selection                                 | 17 15A breaker for control electrical circuits                                   |
| 8 Red Emergency Stop button  | 18 Z-45/25J models only: Jib boom up/down switch                                 |
| 9 Gasoline/LPG models: Check engine light<br>Diesel models: Oil pressure light | 19 Platform level switch   |
| 10 Hour meter  |  |

CONTROLS

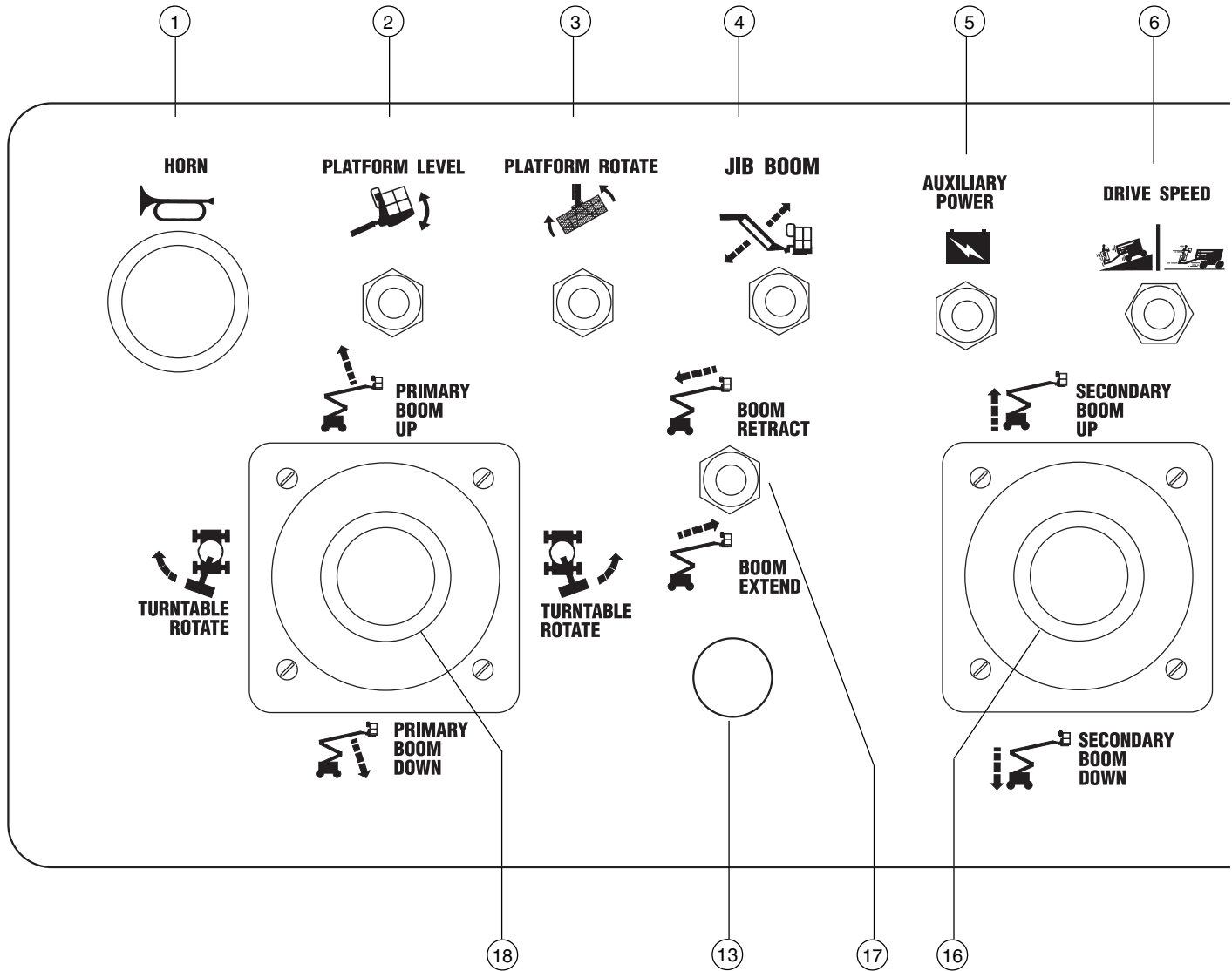

**Platform Control Panel**

- |   |   |
|---|---|
| <ul style="list-style-type: none"> <li>1 Horn button</li> <li>2 Platform level switch</li> <li>3 Platform rotate switch</li> <li>4 Z-45/25J models only: Jib boom up/down switch</li> <li>5 Auxiliary power switch</li> </ul> | <ul style="list-style-type: none"> <li>6 Drive speed select switch</li> <li>7 Glow plug switch</li> <li>8 Engine start switch</li> <li>9 Engine idle (rpm) select switch</li> <li>10 Gasoline/LPG models: Gasoline/LPG select switch</li> </ul> |
|---|---|

CONTROLS

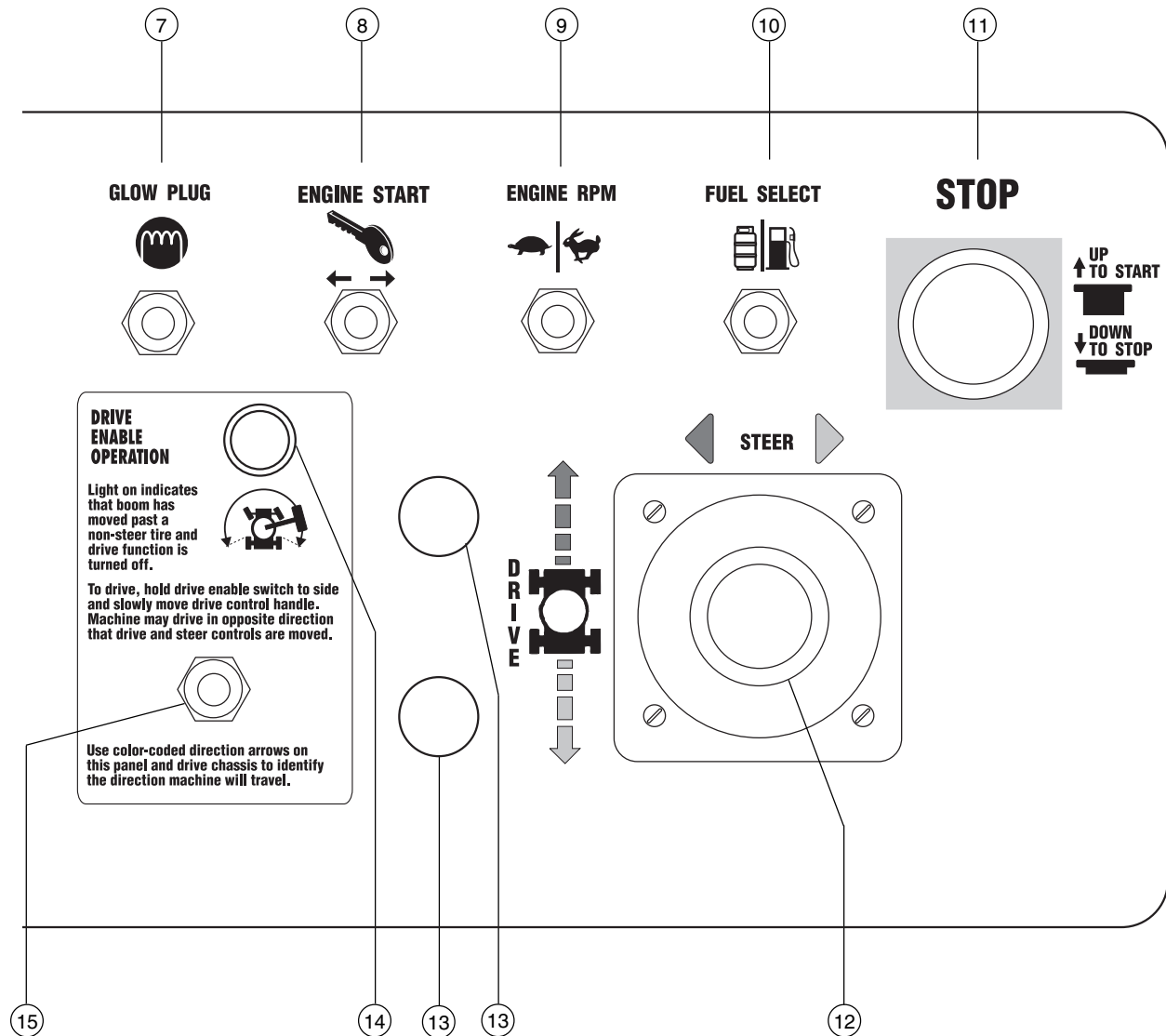

- 11 Red Emergency Stop button
- 12 Dual axis proportional control handle for drive and steer functions  
OR Proportional control handle for drive function and thumb rocker for steer function
- 13 used for optional equipment
- 14 Drive enable indicator light
- 15 Drive enable switch
- 16 Proportional control handle for secondary boom up/down function
- 17 Primary boom extend/retract switch
- 18 Dual axis proportional control handle for primary boom up/down and turntable rotate left/right functions

# Pre-operation Inspection



---

## Do Not Operate Unless:

- You learn and practice the principles of safe machine operation contained in this operator's manual.

1 Avoid hazardous situations.

**2 Always perform a pre-operation inspection.**

**Know and understand the pre-operation inspection before going on to the next section.**

3 Always perform function tests prior to use.

4 Inspect the workplace.

5 Only use the machine as it was intended.

## Fundamentals

It is the responsibility of the operator to perform a Pre-operation Inspection and routine maintenance.

The Pre-operation Inspection is a visual inspection performed by the operator prior to each work shift. The inspection is designed to discover if anything is apparently wrong with a machine before the operator performs the function tests.

The Pre-operation inspection also serves to determine if routine maintenance procedures are required. Only routine maintenance items specified in this manual may be performed by the operator.

Refer to the list on the next page and check each of the items and locations for modifications, damage or loose or missing parts.

A damaged or modified machine must never be used. If damage or any variation from factory delivered condition is discovered, the machine must be tagged and removed from service.

Repairs to the machine may only be made by a qualified service technician, according to the manufacturer's specifications. After repairs are completed, the operator must perform a pre-operation inspection again before going on to the function tests.

Scheduled maintenance inspections shall be performed by qualified service technicians, according to the manufacturer's specifications and the requirements listed in the responsibilities manual.

## PRE-OPERATION INSPECTION

## Pre-operation Inspection

---

- Be sure that the operator's, safety and responsibilities manuals are complete, legible and in the storage container located in the platform.
- Be sure that all decals are legible and in place. See Decals section.
- Check for engine oil leaks and proper oil level. Add oil if needed. See Maintenance section.
- Check for hydraulic oil leaks and proper oil level. Add oil if needed. See Maintenance section.
- Check for engine coolant leaks and proper level of coolant. Add coolant if needed. See Maintenance section.
- Check for battery fluid leaks and proper fluid level. Add distilled water if needed. See Maintenance section.
- Z-45/25 RT and Z-45/25J RT models: Check for proper tire pressure. Add air if needed. See Maintenance section.

Check the following components or areas for damage and improperly installed, loose or missing parts:

- Electrical components, wiring and electrical cables
- Hydraulic hoses, fittings, cylinders and manifolds
- Fuel and hydraulic tanks
- Drive and turntable motors and drive hubs
- Boom wear pads
- Tires and wheels

- Engine and related components
- Limit switches and horn
- Alarms and beacons (if equipped)
- Nuts, bolts and other fasteners
- Platform entry mid-rail or gate

Check entire machine for:

- Crack in welds or structural components
- Dents or damage to machine
- Be sure that all structural and other critical components are present and all associated fasteners and pins are in place and properly tightened.
- After you complete your inspection, be sure that all compartment covers are in place and latched.

# Maintenance



## Observe and Obey:

- ☑ Only routine maintenance items specified in this manual shall be performed by the operator.
- ☑ Scheduled maintenance inspections shall be completed by qualified service technicians, according to the manufacturer's specifications and the requirements specified in the responsibilities manual.

## Maintenance Symbols Legend

### NOTICE

The following symbols have been used in this manual to help communicate the intent of the instructions. When one or more of the symbols appear at the beginning of a maintenance procedure, it conveys the meaning below.



Indicates that tools will be required to perform this procedure.



Indicates that new parts will be required to perform this procedure.



Indicates that a cold engine is required before performing this procedure.

## Check the Engine Oil Level



Maintaining the proper engine oil level is essential to good engine performance and service life. Operating the machine with an improper oil level can damage engine components.

### NOTICE

Check the oil level with the engine off.

- 1 Check the oil dipstick.

### Ford models:

- ⊙ Result: The oil level should be between the ADD and SAFE marks. Add oil as needed.

### Deutz models:

- ⊙ Result: The oil level should be within the two marks on the dipstick. Add oil as needed.

### Perkins Models:

- ⊙ Result: The oil level should be within the two notches on the dipstick.

---

### Ford LRG-425 EFI Engine Oil viscosity requirements

---

below 60°F / 15.5°C	5W-30
-10° to 90°F / -23° to 32°C	5W-30
above -10°F / -23°C	5W-30
above 25°F / -4°C	10W-30

Use oils meeting API classification SH or SG.  
Units ship with 10-40 CC/SG.

---

MAINTENANCE

---

**Deutz Engine F3L 1011F**  
**Oil viscosity requirements**

below 60°F / 15.5°C (synthetic)	5W-30
-10°F to 90°F / -23°C to 32°C	10W-40
above -4°F / -34°C	15W-40

Engine oil should have properties of API classification CC/SE, CD/SE, SF/CC or SF/CD grades.  
 Units ship with 10-40 CC/SG.

---

**Perkins Engine 104-22**  
**Oil viscosity requirements**

below 60°F / 15.5°C	5W-20
-10° to 90°F / -23° to 32°C	10W-30
above -10°F / -23°C	15W-40
above 25°F / -4°C	20W-50

Engine oil should have properties of API classification CC/SE, CD/SE, SF/CC or SF/CD grades.  
 Units ship with 10-40 CC/SG.

---

## Check the Hydraulic Oil Level



Maintaining the hydraulic oil at the proper level is essential to machine operation. Improper hydraulic oil levels can damage hydraulic components. Daily checks allow the inspector to identify changes in oil level that might indicate the presence of hydraulic system problems.

- 1 Be sure that the boom is in the stowed position, then visually inspect the sight gauge located on the side of the hydraulic oil tank.
- ⊙ Result: The hydraulic oil level should be within the top 2 inches / 5 cm of the sight gauge.
- 2 Add oil as needed.

---

**Hydraulic oil specifications**

Hydraulic oil type	Dexron equivalent
--------------------	-------------------

---

## MAINTENANCE

## Check the Engine Coolant Level - Ford and Perkins Models



Maintaining the engine coolant at the proper level is essential to engine service life. Improper coolant level will affect the engine's cooling capability and damage engine components. Daily checks will allow the inspector to identify changes in coolant level that might indicate cooling system problems.

**CAUTION** Burn hazard. Beware of hot engine parts and coolant. Contact with hot engine parts and/or coolant may cause severe burns.

- 1 Check the fluid level in the coolant recovery tank. Add fluid as needed.
- ⦿ Result: The fluid level should be at the FULL mark.

**NOTICE** Do not remove the radiator cap.

## Check the Batteries



Proper battery condition is essential to good engine performance and operational safety. Improper fluid levels or damaged cables and connections can result in engine component damage and hazardous conditions.

**WARNING** Electrocution hazard. Contact with hot or live circuits may result in death or serious injury. Remove all rings, watches and other jewelry.

**WARNING** Bodily injury hazard. Batteries contain acid. Avoid spilling or contacting battery acid. Neutralize battery acid spills with baking soda and water.

- 1 Put on protective clothing and eye wear.
- 2 Be sure that the battery cable connections are tight and free of corrosion.
- 3 Be sure that the battery hold-down bracket is secure.
- 4 Remove the battery vent caps.
- 5 Check the battery acid level. If needed, replenish with distilled water to the bottom of the battery fill tube. Do not overfill.
- 6 Install the vent caps.

**NOTICE** Adding terminal protectors and a corrosion preventative sealant will help eliminate corrosion on the battery terminals and cables.



MAINTENANCE

## Check the Tire Pressure



**⚠ WARNING** Bodily injury hazard. An over-inflated tire can explode, which can result in death or serious injury.

**⚠ WARNING** Tip-over hazard. Do not use temporary flat tire repair products.

**ℹ NOTICE** This procedure does not need to be performed on machines equipped with foam-filled tires.

To safeguard maximum stability, achieve optimum machine handling and minimize tire wear, it is essential to maintain proper pressure in all air-filled tires.

- 1 Check each tire with an air pressure gauge and add air as needed.

Tire specifications	2WD Models	4WD Models
Narrow base models		
Industrial tire	Foam Filled Only	
Standard base models		
Rough terrain tire	14-17.5 NHS 45 psi / 3.1 bar	14-17.5 NHS 45 psi / 3.1 bar

## Scheduled Maintenance

Maintenance performed quarterly, annually and every two years must be completed by a person trained and qualified to perform maintenance on this machine according to the procedures found in the service manual for this machine.

Machines that have been out of service for more than three months must receive the quarterly inspection before they are put back into service.

# Function Tests



---

## Do Not Operate Unless:

- ☑ You learn and practice the principles of safe machine operation contained in this operator's manual.

- 1 Avoid hazardous situations.
- 2 Always perform a pre-operation inspection.

### **3 Always perform function tests prior to use.**

#### **Know and understand the function tests before going on to the next section.**

- 4 Inspect the workplace.
- 5 Only use the machine as it was intended.

## Fundamentals

The Function Tests are designed to discover any malfunctions before the machine is put into service. The operator must follow the step-by-step instructions to test all machine functions.

A malfunctioning machine must never be used. If malfunctions are discovered, the machine must be tagged and removed from service. Repairs to the machine may only be made by a qualified service technician, according to the manufacturer's specifications.

After repairs are completed, the operator must perform a pre-operation inspection and function tests again before putting the machine into service.

## Symbol Legend

- ⦿ Indicates that a specific result is expected after performing a series of steps.

## FUNCTION TESTS

- 1 Select a test area that is firm, level and free of obstruction.

### At the Ground Controls

- 2 Turn the key switch to ground control.
- 3 Pull out the red Emergency Stop button to the on position.
- ⦿ Result: Beacon (if equipped) should flash.
- 4 Start the engine. See Operating Instruction section.

### Test Emergency Stop

- 5 Push in the red Emergency Stop button to the off position.
- ⦿ Result: The engine will shut off after 2 to 3 seconds.
- 6 Pull out the red Emergency Stop button to the on position and restart the engine.

### Test the Machine Functions

- 7 Do not hold the function enable switch to either side. Attempt to activate each boom and platform function toggle switch.
- ⦿ Result: All boom and platform functions should not operate.
- 8 Hold the function enable switch to either side and activate each boom and platform function toggle switch.
- ⦿ Result: All boom and platform functions should operate through a full cycle. The descent alarm (if equipped) should sound while the boom is lowering.

Machines equipped with Platform Level Control Disable Function: The platform level toggle switch will not operate when the primary boom is raised past the drive speed limit switch.

### Test the Tilt Sensor

- 9 Pull out the platform red Emergency Stop button to the on position. Turn the key switch to platform control.
- 10 Open the engine side turntable cover and locate the tilt sensor to the right of the hydraulic pump.
- 11 Press down one side of the tilt sensor.

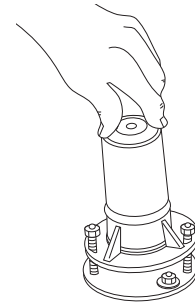

- ⦿ Result: The alarm, located in the platform, should sound.

### Test Auxiliary Controls

- 12 Turn the key switch to ground control and shut the engine off.
- 13 Pull out the red Emergency Stop button to the on position.
- 14 Simultaneously hold the auxiliary power switch on and activate each boom function toggle switch.

Note: To conserve battery power, test each function through a partial cycle.

- ⦿ Result: All boom functions should operate.

## FUNCTION TESTS

**At the Platform Controls****Test Emergency Stop**

- 15 Turn the key switch to platform control and restart the engine.
- 16 Push in the platform red Emergency Stop button to the off position.
  - ⦿ Result: The engine will shut off after 2 or 3 seconds.
- 17 Pull out the red Emergency Stop button and restart the engine.

**Test the Horn**

- 18 Push the horn button.
  - ⦿ Result: The horn should sound.

**Test the Foot Switch**

- 19 Push in the platform red Emergency Stop button to the off position.
- 20 Pull out the red Emergency Stop button to the on position but do not start the engine.
- 21 Press down the foot switch and attempt to start the engine by moving the start toggle switch to either side.
  - ⦿ Result: The engine should not start.
- 22 Do not press down the foot switch and restart the engine.
  - ⦿ Result: The engine should start.
- 23 Move the lift/drive select switch to the lift position (if equipped).
- 24 Do not press down the foot switch and test each machine function.
  - ⦿ Result: The machine functions should not operate.

**Test Machine Functions**

- 25 Press down the foot switch.
- 26 Activate each machine function control handle or toggle switch.
  - ⦿ Result: All boom/platform functions should operate through a full cycle.

Machines equipped with Platform Level Control Disable Function: The platform level toggle switch will not operate when the primary boom is raised past the drive speed limit switch.

**Test the Steering**

- 27 Move the lift/drive select switch to the drive position (if equipped).
- 28 Press down the foot switch.
- 29 Press the thumb rocker switch on top of the drive control handle in the direction indicated by the blue triangle on the control panel OR slowly move the control handle in the direction indicated by the blue triangle.
  - ⦿ Result: The steer wheels should turn in the direction that the blue triangles point on the drive chassis.
- 30 Press the thumb rocker switch on top of the drive control handle in the direction indicated by the yellow triangle on the control panel OR slowly move the control handle in the direction indicated by the yellow triangle.
  - ⦿ Result: The steer wheels should turn in the direction that the yellow triangles point on the drive chassis.

## FUNCTION TESTS

**Test Drive and Braking**

- 31 Press down the foot switch.
- 32 Slowly move the drive control handle in the direction indicated by the blue arrow on the control panel until the machine begins to move, then return the handle to the center position.
- ⦿ Result: The machine should move in the direction that the blue arrow points on the drive chassis, then come to an abrupt stop.
- 33 Slowly move the drive control handle in the direction indicated by the yellow arrow on the control panel until the machine begins to move, then return the handle to the center position.
- ⦿ Result: The machine should move in the direction that the yellow arrow points on the drive chassis, then come to an abrupt stop.

Note: The brakes must be able to hold the machine on any slope it is able to climb.

**Test the Drive Enable System**

- 34 Move the lift/drive select switch to the lift position (if equipped).
- 35 Press down the foot switch and lower the boom to the stowed position.
- 36 Rotate the turntable until the primary boom moves past one of the non-steer wheels.
- ⦿ Result: The drive enable indicator light should come on and remain on while the boom is anywhere in the range shown.
- 37 Move the lift/drive select switch to the drive position (if equipped).
- 38 Move the drive control handle off center.
- ⦿ Result: The drive function should not operate.
- 39 Move and hold the drive enable toggle switch to either side and slowly move the drive control handle off center.
- ⦿ Result: The drive function should operate.

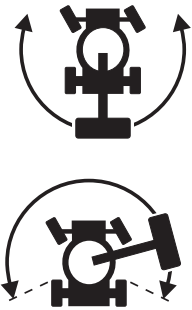

Note: When the drive enable system is in use, the machine may drive in the opposite direction that the drive and steer control handle is moved.

Use the color-coded direction arrows on the platform controls and the drive chassis to identify the direction of travel.

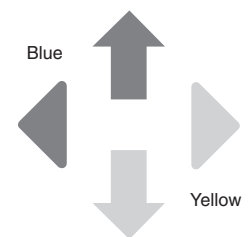

## FUNCTION TESTS

**Test Limited Drive Speed****Z-45/25 & Z-45/25J Standard Base Models****ANSI and CSA Z-45/25 & Z-45/25J Narrow Base Models before serial number 19081**

- 40 Move the lift/drive select switch to the lift position (if equipped).
- 41 Press down the foot switch.
- 42 Raise the primary boom approximately 2 feet / 61 cm.
- 43 Move the lift/drive select switch to the drive position (if equipped).
- 44 Slowly move the drive control handle to the full drive position.
- ⊙ Result: The maximum achievable drive speed with the primary boom raised should not exceed 1 foot / 30 cm per second.
- 45 Move the lift/drive select switch to the lift position (if equipped).
- 46 Lower the primary boom to the stowed position.
- 47 Raise the secondary boom approximately 2 feet / 61 cm.
- 48 Move the lift/drive select switch to the drive position (if equipped).
- 49 Slowly move the drive control handle to the full drive position.
- ⊙ Result: The maximum achievable drive speed with the secondary boom raised should not exceed 1 foot / 30 cm per second.

- 50 Move the lift/drive select switch to the lift position (if equipped).
- 51 Lower the secondary boom to the stowed position.
- 52 Extend the primary boom approximately 1 foot / 30 cm.
- 53 Move the lift/drive select switch to the drive position (if equipped).
- 54 Slowly move the drive control handle to the full drive position.
- ⊙ Result: The maximum achievable drive speed with the primary boom extended should not exceed 1 foot / 30 cm per second.
- 55 Move the lift/drive select switch to the lift position (if equipped).
- 56 Retract the boom to the stowed position.

If the drive speed with the primary boom raised, the secondary boom raised or the primary boom extended exceeds 1 foot / 30 cm per second, immediately tag and remove the machine from service.

**Test Limited Drive Speed****CE Z-45/25 & Z-45/25J Narrow Base Models before serial number 19081****All Z-45/25 & Z-45/25J Narrow Base Models after serial number 19080**

- 40 Move the lift/drive select switch to the lift position (if equipped).
- 41 Press down the foot switch.

## FUNCTION TESTS

- 42 Raise the primary boom approximately 2 feet / 61 cm.
- 43 Move the lift/drive select switch to the drive position (if equipped).
- 44 Slowly move the drive control handle to the full drive position.
- ⦿ Result: The maximum achievable drive speed with the primary boom raised should not exceed 0.5 foot / 15 cm per second.
- 45 Move the lift/drive select switch to the lift position (if equipped).
- 46 Lower the primary boom to the stowed position.
- 47 Raise the secondary boom approximately 2 feet / 61 cm.
- 48 Move the lift/drive select switch to the drive position (if equipped).
- 49 Slowly move the drive control handle to the full drive position.
- ⦿ Result: The maximum achievable drive speed with the secondary boom raised should not exceed 0.5 foot / 15 cm per second.
- 50 Move the lift/drive select switch to the lift position (if equipped).
- 51 Lower the secondary boom to the stowed position.
- 52 Extend the primary boom approximately 1 foot / 30 cm.
- 53 Move the lift/drive select switch to the drive position (if equipped).
- 54 Slowly move the drive control handle to the full drive position.
- ⦿ Result: The maximum achievable drive speed with the primary boom extended should not exceed 0.5 foot / 15 cm per second.
- 55 Move the lift/drive select switch to the lift position (if equipped).
- 56 Retract the boom to the stowed position.
- If the drive speed with the primary boom raised, the secondary boom raised or the primary boom extended exceeds 0.5 foot / 15 cm per second, immediately tag and remove the machine from service.
- Test the Oscillate Axle  
(oscillating axle-equipped models)**
- 57 Move the lift/drive select switch to the drive position (if equipped).
- 58 Start the engine from the platform controls.
- 59 Drive the right steer tire up onto a 6 inch / 15.2 cm block or curb.
- ⦿ Result: The three remaining tires should stay in firm contact with the ground.
- 60 Drive the left steer tire up onto a 6 inch / 15.2 cm block or curb.
- ⦿ Result: The three remaining tires should stay in firm contact with the ground.
- 61 Drive both steer tires up onto a 6 inch / 15.2 cm block or curb.
- ⦿ Result: The non-steer tires should stay in firm contact with the ground.

## FUNCTION TESTS

**Test Auxiliary Controls**

- 62 Shut the engine off.
- 63 Pull out the red Emergency Stop button to the on position.
- 64 Move the lift/drive select switch to the lift position (if equipped).
- 65 Press down the foot switch.
- 66 Simultaneously hold the auxiliary power switch on and activate each function control handle or toggle switch.

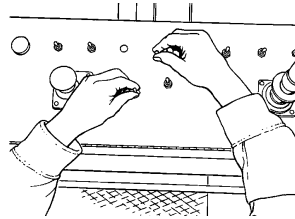

Note: To conserve battery power, test each function through a partial cycle.

- ⊙ Result: All boom and steer functions should operate. Drive functions should not operate with auxiliary power.

**Test the Lift/Drive Select Function (CE models)****Machines with lift/drive select switch:**

- 67 Move the lift/drive select switch to the lift position.
- 68 Press down the foot switch.
- 69 Move the drive control handle off center.
- ⊙ Result: No drive functions should operate.
- 70 Activate each boom function toggle switch.
- ⊙ Result: All boom functions should operate.
- 71 Move the lift/drive select switch to the drive position.
- 72 Press down the foot switch.
- 73 Activate each boom function toggle switch.
- ⊙ Result: No boom functions should operate.
- 74 Move the drive control handle off center.
- ⊙ Result: The drive functions should operate.
- 75 Repair any malfunctions before operating the machine.

**Machines without lift/drive select switch:**

- 76 Press down the foot switch.
- 77 Move the drive control handle off center and activate a boom function toggle switch.
- ⊙ Result: No boom functions should operate. The machine will move in the direction indicated on the control panel.
- 78 Repair any malfunctions before operating the machine.



---

# Workplace Inspection



---

## Do Not Operate Unless:

- You learn and practice the principles of safe machine operation contained in this operator's manual.

- 1 Avoid hazardous situations.
- 2 Always perform a pre-operation inspection.
- 3 Always perform function tests prior to use.

### **4 Inspect the workplace.**

**Know and understand the workplace inspection before going on to the next section.**

- 5 Only use the machine as it was intended.

## Fundamentals

The Workplace Inspection helps the operator determine if the workplace is suitable for safe machine operation. It should be performed by the operator prior to moving the machine to the workplace.

It is the operator's responsibility to read and remember the workplace hazards, then watch for and avoid them while moving, setting up and operating the machine.

## Workplace Inspection

Be aware of and avoid the following hazardous situations:

- drop-offs or holes
- bumps, floor obstructions or debris
- overhead obstructions and high voltage conductors
- hazardous locations
- inadequate surface support to withstand all load forces imposed by the machine
- wind and weather conditions
- the presence of unauthorized personnel
- other possible unsafe conditions

---

# Operating Instructions



---

## Do Not Operate Unless:

- You learn and practice the principles of safe machine operation contained in this operator's manual.
  - 1 Avoid hazardous situations.
  - 2 Always perform a pre-operation inspection.
  - 3 Always perform function tests prior to use.
  - 4 Inspect the workplace.
  - 5 Only use the machine as it was intended.**

## Fundamentals

The Operating Instructions section provides instructions for each aspect of machine operation. It is the operator's responsibility to follow all the safety rules and instructions in the operator's, safety and responsibilities manuals.

Using the machine for anything other than lifting personnel and tools to an aerial work site is unsafe and dangerous.

Only trained and authorized personnel should be permitted to operate a machine. If more than one operator is expected to use a machine at different times in the same work shift, they must all be qualified operators and are all expected to follow all safety rules and instructions in the operator's, safety and responsibilities manuals. That means every new operator should perform a pre-operation inspection, function tests, and a workplace inspection before using the machine.

## OPERATING INSTRUCTIONS

## Starting the Engine

- 1 At the ground controls, turn the key switch to the desired position.
- 2 Be sure both ground and platform control red Emergency Stop buttons are pulled out to the on position.
- 3 Gasoline/LPG models: Choose fuel by moving the fuel select switch to the desired position.
- 4 Move the engine start toggle switch to either side. If the engine fails to start or dies, the restart delay will disable the start switch for 3 seconds.



If the engine fails to start after 15 seconds of cranking, determine the cause and repair any malfunction. Wait 60 seconds before trying to start again.

All models: In extreme cold conditions, 20°F / -6°C and below, warm the engine for 5 minutes to prevent hydraulic system damage.

Gasoline/LPG models: In extreme cold conditions, 20°F / -6°C and below, the machine should be started on gasoline, then switched to LPG.

## Emergency Stop

Push in either ground or platform red Emergency Stop button to the off position to stop all functions and turn the engine off.

Repair any function that operates when the red Emergency Stop button is pushed in.

Selecting and operating the ground controls will override the platform red Emergency Stop button.

## Auxiliary Controls

Use auxiliary power if the primary power source (engine) fails.

- 1 Turn the key switch to ground or platform control.
- 2 Pull out the red Emergency Stop button to the on position.
- 3 Move the lift/drive select switch to the lift position when operating the auxiliary controls from the platform.
- 4 Press down the foot switch when operating the auxiliary controls from the platform.
- 5 Simultaneously hold auxiliary power switch on and activate the desired function.

The drive and steer functions will not operate with auxiliary power.

## Operation from Ground

- 1 Turn the key switch to ground control.
- 2 Pull out the red Emergency Stop button to the on position.
- 3 Gasoline/LPG models: Choose fuel by moving the fuel select switch to the desired position.
- 4 Start the engine.

---

## OPERATING INSTRUCTIONS

### To Position Platform

- 1 Hold the function enable switch to either side.
- 2 Move the appropriate toggle switch according to the markings on the control panel.

Drive and steer functions are not available from the ground controls.

Machines equipped with Platform Level Control Disable Function: The platform level toggle switch will not operate when the primary boom is raised past the drive speed limit switch.

### Operation from Platform

- 1 Turn the key switch to platform control.
- 2 Pull out both ground and platform red Emergency Stop buttons to the on position.
- 3 Gasoline/LPG models: Choose fuel by moving the fuel select switch to the desired position.
- 4 Start the engine. Do not press down the foot switch when starting the engine.

### To Position Platform

- 1 Move the lift/drive select switch to the lift position (if equipped).
- 2 Press down the foot switch.
- 3 Slowly move the appropriate function control handle or toggle switch according to the markings on the control panel.

Machines equipped with Platform Level Control Disable Function: The platform level toggle switch will not operate when the primary boom is raised past the drive speed limit switch.

### To Steer

- 1 Move the lift/drive select switch to the drive position (if equipped).
- 2 Press down the foot switch.
- 3 Slowly move the control handle in the direction indicated by blue or yellow triangles  
OR press the thumb rocker switch located on top of the drive control handle.

Use the color-coded direction arrows on the platform controls and the drive chassis to identify the direction the wheels will turn.

### To Drive

- 1 Move the lift/drive select switch to the drive position (if equipped).
- 2 Press down the foot switch.
- 3 Increase speed: Slowly move the drive control handle off center.  
Decrease speed: Slowly move the drive control handle toward center.  
Stop: Return the drive control handle to center or release the foot switch.

Use the color-coded direction arrows on the platform controls and the drive chassis to identify the direction the machine will travel.

Machine travel speed is restricted when the booms are raised.

## OPERATING INSTRUCTIONS

**Drive Enable**

Light on indicates that the boom has moved just past either non-steer wheel and the drive function has been interrupted.

To drive, hold the drive enable switch to either side and slowly move the drive control handle off center.

Be aware that the machine may move in the opposite direction that the drive and steer controls are moved.

Always use the color-coded direction arrows on the platform controls and the drive chassis to identify the direction the machine will travel.

**Generator**

To operate the generator, move the generator toggle switch to the generator position. The engine will continue to run but no drive or platform functions will operate.

Plug a power tool into the power to platform GFCI outlet.

To resume machine functions, move the generator toggle switch to machine functions position. All functions will operate.

**Drive Speed Select**

- Machine on incline symbol: Low range operation for inclines
- Machine on level surface symbol: High range operation for maximum drive speed

**Engine Idle Select (rpm)**

Select the engine idle speed (rpm) using the symbols on the control panel.

If your control panel looks like this:

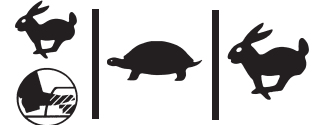

- Rabbit and foot switch symbol: foot switch activated high idle

- Turtle symbol: low idle
- Rabbit symbol: high idle

If your control panel looks like this:



When the foot switch is not pressed, the engine will idle at the lowest rpm.

- Turtle symbol: Foot switch activated low idle
- Rabbit symbol: Foot switch activated high idle

## OPERATING INSTRUCTIONS

**Check Engine Light  
(if equipped)**

Light on and engine stopped: Tag the machine and remove from service.

Light on and engine still running: Contact service personnel within 24 hours.

**Stopping the Engine**

Push in the red Emergency Stop button and turn the key switch to the off position.

**After Each Use**

- 1 Select a safe parking location—firm level surface, clear of obstruction and traffic.
- 2 Retract and lower the boom to the stowed position.
- 3 Rotate the turntable so that the boom is between the non-steer wheels.
- 4 Turn the key switch to the off position and remove the key to secure from unauthorized use.
- 5 Chock the wheels.

# Transport



## Transport Instructions Observe and Obey:

- ☑ The transport vehicle must be parked on a level surface.
- ☑ The transport vehicle must be secured to prevent rolling while the machine is being loaded.
- ☑ Be sure the vehicle capacity, loading surfaces and chains or straps are sufficient to withstand machine weight. See the serial plate for the machine weight.
- ☑ Be sure the turntable is secured with the turntable rotation lock before transporting. Be sure to unlock the turntable for operation.

## Securing to Truck or Trailer for Transit

Always chock the machine wheels in preparation for transport.

Use the tie points on the drive chassis for anchoring down to the transport surface.

Use the rotator guard under the platform to secure the boom from side-to-side movement. Do not use excessive downward force when securing the boom section.

Use chains or straps of ample load capacity.

Turn the key switch to the off position and remove the key before transporting.

Inspect the entire machine for loose or unsecured items.

## Free-wheel Configuration for Winching

Chock the wheels to prevent the machine from rolling.

Release the non-steer wheel brakes by turning over the drive hub disconnect caps (see below).

Be sure the winch line is properly secured to the drive chassis tie points and the path is clear of all obstructions.

Reverse the procedures described to re-engage the brakes.

Note: Towing the Genie Z-45/25 or the Z-45/25J is not recommended. If the machine must be towed, do not exceed 2 mph / 3.2 km/h.

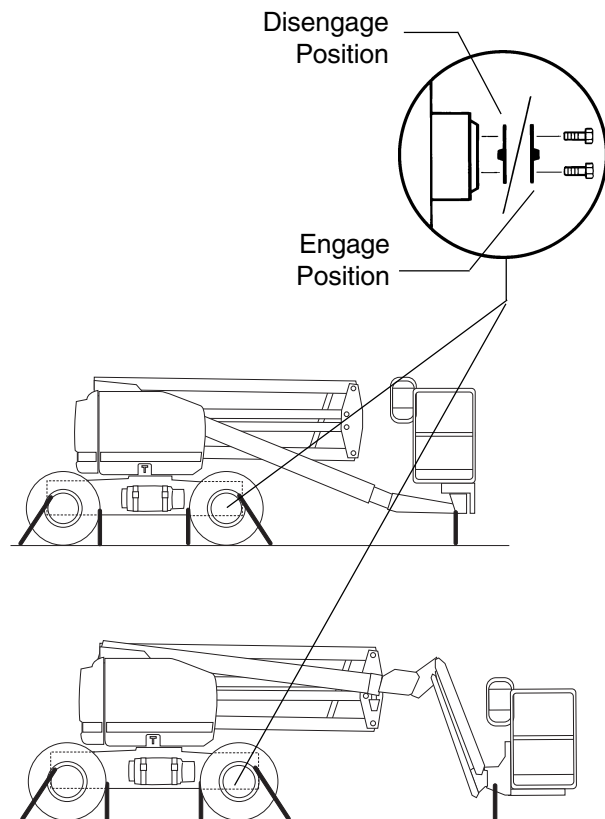

# Decals

## Decal Inspection

Use the pictures on this and the next page to verify that all decals are legible and in place.

Below is a numerical list with quantities and descriptions.

Part No.	Decal Description	Quantity
25994	Caution - Component Damage Hazard	1
27204	Arrow - Blue	1
27205	Arrow - Yellow	1
27206	Triangle- Blue	2
27207	Triangle - Yellow	2
27564	Danger - Electrocution Hazard	2
28157	Label - Dexron	1
28158	Label - Unleaded	1
28159	Label - Diesel	1
28160	Label - Liquid Petroleum Gas	2
28161	Warning - Crushing Hazard	3
28163	Notice - Max Side Force, 150 lbs / 667N	1
28164	Notice - Hazardous Materials	1
28165	Notice - Foot Switch	1
28171	Label - No Smoking	1
28174	Label - Power to Platform, 230V	2
28175	Caution - Compartment Access	1
28176	Notice - Missing Manuals	1
28177	Warning - Platform Rotate	2
28181	Warning - No Step or Ride	1
28235	Label - Power to Platform, 115V	2
28236	Warning - Failure To Read . . .	1
30080	Notice - Maximum Load	1
31060	Danger - Tip-over Hazard, Interlock	3
32700	Danger - Safety Rules	2
32728	Generator (option)	1

Part No.	Decal Description	Quantity
33550	Safety Tape	—
33952	Danger - Tilt-Alarm	1
40434	Label - Lanyard Anchorage Point	3
43595	Danger - Tip-over Hazard, Tires	4
43663	Notice - Function Enable	1
43647	Notice - Operating Instructions	2
44769	Lift/Drive Select (option)	1
44981	Airline to Platform	2
44986	Notice - Max Manual Force, 90 lbs / 400N	1
49741	Notice - Ford Engine Spec LRG-425 EFI	1
52230	Platform Control Panel	1
52447	Label - Tire Pressure	4
52511	Ground Control Panel	1
52607	Label - Test Switch	1
52672	Danger - Tip-over Hazard, Tires	4
52784	Notice - Deutz Diesel Specifications	1
52968	Cosmetic - Genie Boom	1
62926	Cosmetic - Genie Z-45/25J	1
62927	Cosmetic - Genie Z-45/25	1
62947	Cosmetic - IC Power 4 x 2	1
62948	Cosmetic - IC Power 4 x 4	1
65301	Notice - Foam-Filled Tire Specs	4
72441	Platform Control Panel	1
72442	Ground Control Panel	1
82238	Platform Control Panel	1
82283	Notice - Operating Instructions	2



DECALS

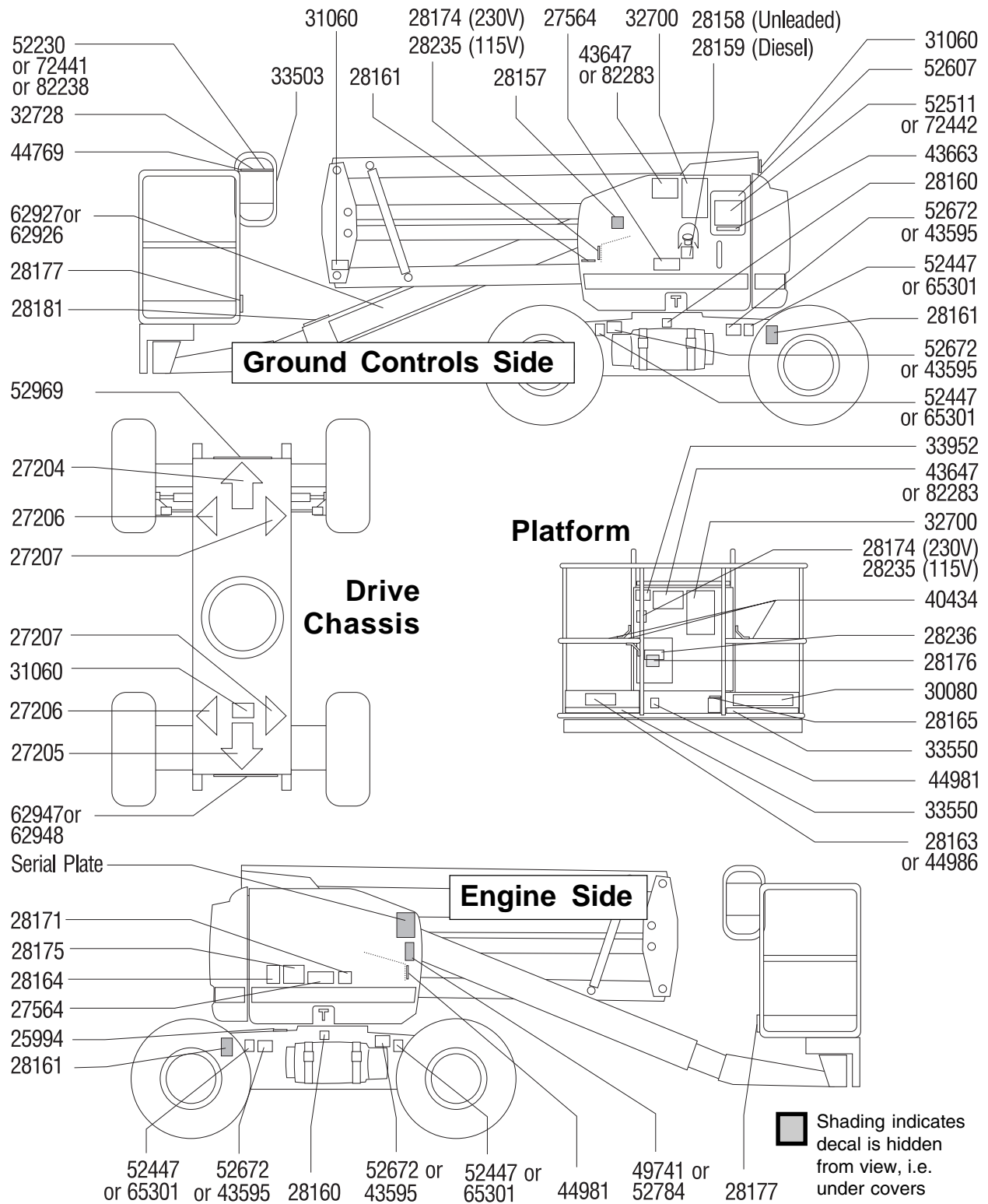

# Specifications

Standard Base Models	Z-45/25 (no jib)	Z-45/25J (jib)
Height, working maximum	51 ft 8 in 15.74 m	51 ft 6 in 15.69 m
Height, platform maximum	45 ft 8 in 13.9 m	45 ft 6 in 13.8 m
Height, stowed maximum	6 ft 10 in 2.1 m	6 ft 10 in 2.1 m
Horizontal reach maximum	<sup>1</sup> 24 ft 6 in 7.5 m	25 ft 3 in 7.7 m
Width	7 ft 4 in 2.2 m	7 ft 4 in 2.2 m
Length, stowed	18 ft 5.5 m	22 ft 3 in 6.8 m
Maximum load capacity 6 foot platform	500 lb 227 kg	500 lb 227 kg
Wheelbase	6 ft 8 in 2.0 m	6 ft 8 in 2.0 m
Turning radius (outside)	11 ft 6 in 3.5 m	11 ft 6 in 3.5 m
Turning radius (inside)	4 ft 6 in 1.4 m	4 ft 6 in 1.4 m
Turntable rotation (degrees)	359°	359°
Turntable tailswing	0 in 0 cm	0 in 0 cm
Power source (choice)	Ford Gasoline/LPG LRG 425 EFI OR Deutz Diesel F3L 1011	
Drive speed, stowed	4.8 mph 7.7 km/h 40 ft/5.7 sec 12.2 m/5.7 sec	4.8 mph 7.7 km/h 40 ft/5.7 sec 12.2 m/5.7 sec
Drive speed, booms raised	0.6 mph 1 km/h 40 ft/45 sec 12.2 m/45 sec	0.6 mph 1 km/h 40 ft/45 sec 12.2 m/45 sec
Airborne noise emissions Maximum sound level at normal operating workstations (A-weighted)	73 dB	73 dB
Ground clearance center	13.25 in 33.6 cm	13.25 in 33.6 cm
Ground clearance minimum	10 in 25.4 cm	10 in 25.4 cm

Standard Base Models	Z-45/25 (no jib)	Z-45/25J (jib)
Controls	12V DC proportional	
Weight (Machine weights vary with option configurations)	See Serial Plate	
Platform dimensions, 6 foot (length x width)	72 in x 30 in 1.8 m x 76 cm	72 in x 30 in 1.8 m x 76 cm
Platform leveling	self-leveling	self-leveling
Platform rotation	180 degrees	160 degrees
AC outlet in platform	standard	standard
Hydraulic pressure (maximum) (boom functions)	3200 psi 221 bar	3200 psi 221 bar
Tire size, 4WD & 2WD RT	14-17.5 14 ply	
Gradeability, stowed, 2WD	30%	30 %
Gradeability, stowed, 4WD	45%	45 %
Fuel tank capacity	17 gallons 64.3 liters	17 gallons 64.3 liters

<sup>1</sup> Outreach specification with platform rotated 90 degrees

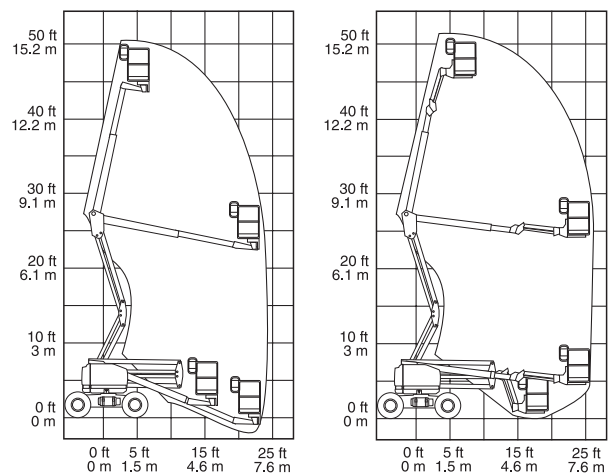

Continuous improvement of our products is a Genie policy. Product specifications are subject to change without notice or obligation.

SPECIFICATIONS

Narrow Base Models	Z-45/25 (no jib)	Z-45/25J (jib)
Height, working maximum	51 ft 5 in 15.7 m	51 ft 3 in 15.6 m
Height, platform maximum	45 ft 5 in 13.9 m	45 ft 3 in 13.8 m
Height, stowed maximum	6 ft 7 in 2.05 m	6 ft 7 in 2.05 m
Horizontal reach maximum	<sup>1</sup> 24 ft 6 in 7.5 m	25 ft 3 in 7.7 m
Width	5 ft 9 in 1.8 m	5 ft 9 in 1.8 m
Length, stowed	18 ft 5.5 m	22 ft 3 in 6.8 m
Maximum load capacity 6 foot platform	500 lb 227 kg	500 lb 227 kg
Wheelbase	6 ft 8 in 2.0 m	6 ft 8 in 2.0 m
Turning radius (outside)	11 ft 3.35 m	11 ft 3.35 m
Turning radius (inside)	5 ft 1.5 m	5 ft 1.5 m
Turntable rotation (degrees)	359°	359°
Turntable tailswing	0 in 0 cm	0 in 0 cm
Power source (choice)	Ford Gasoline/LPG LRG 425 EFI OR Deutz Diesel F3L 1011	
Drive speed, stowed	4.8 mph 7.7 km/h 40 ft/5.7 sec 12.2 m/5.7 sec	4.8 mph 7.7 km/h 40 ft/5.7 sec 12.2 m/5.7 sec
Drive speed, booms raised	0.3 mph 0.5 km/h 40 ft/91 sec 12.2 m/91 sec	0.3 mph 0.5 km/h 40 ft/91 sec 12.2 m/91 sec
Airborne noise emissions Maximum sound level at normal operating workstations (A-weighted)	73 dB	73 dB
Ground clearance center	8.5 in 21.6 cm	8.5 in 21.6 cm
Ground clearance minimum	7 in 17.7 cm	7 in 17.7 cm

Narrow Base Models	Z-45/25 (no jib)	Z-45/25J (jib)
Controls	12V DC proportional	
Weight (Machine weights vary with option configurations)	See Serial Plate	
Platform dimensions, 6 foot (length x width)	72 in x 30 in 1.8 m x 76 cm	72 in x 30 in 1.8 m x 76 cm
Platform leveling	self-leveling	self-leveling
Platform rotation	180 degrees	160 degrees
AC outlet in platform	standard	standard
Hydraulic pressure (maximum) (boom functions)	3200 psi 221 bar	3200 psi 221 bar
Tire size, 2WD Industrial Foam-filled only		9-14.5 LT
Gradeability, stowed, 2WD	30%	30 %
Fuel tank capacity	17 gallons 64.3 liters	17 gallons 64.3 liters

<sup>1</sup> Outreach specification with platform rotated 90 degrees

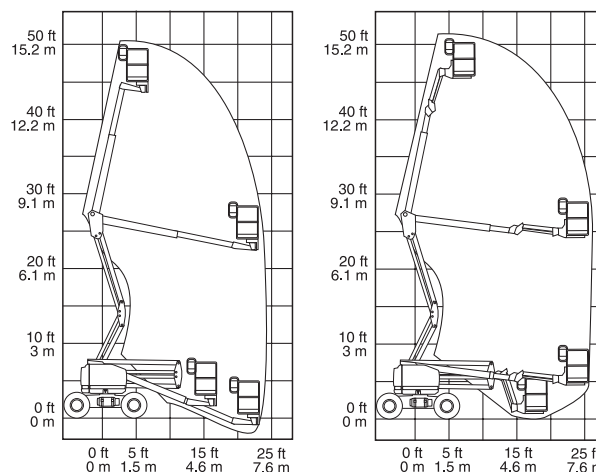

Continuous improvement of our products is a Genie policy. Product specifications are subject to change without notice or obligation.

# California Proposition 65

# WARNING

The exhaust from this product contains chemicals known to the State of California to cause cancer, birth defects or other reproductive harm.

**Genie Holland**

**Phone** +31 70 51 78836  
**Fax** +31 70 51 13993

**Genie Scandinavia**

**Phone** +46 31 3409612  
**Fax** +46 31 3409613

**Genie France**

**Phone** +33 (0)2 37 26 09 99  
**Fax** +33 (0)2 37 26 09 98

**Genie Ibérica**

**Phone** +34 93 579 5042  
**Fax** +34 93 579 5059

**Genie Germany**

**Phone** +49 (0)4202 88520  
**Fax** +49 (0)4202 8852-20

**Genie U.K.**

**Phone** +44 (0)1476 584333  
**Fax** +44 (0)1476 584334

**Genie Mexico City**

**Phone** +52 5 653 03 84  
**Fax** +52 5 664 40 16

**Genie North America**

**Phone** 425.881.1800  
**Toll Free** USA and Canada  
800.536.1800  
**Fax** 425.883.3475

**Genie Australia Pty Ltd.**

**Phone** +61 7 3375 1660  
**Fax** +61 7 3375 1002

**Genie China**

**Phone** +86 21 53852570  
**Fax** +86 21 53852569

**Genie Malaysia**

**Phone** +60 4 228 1235  
**Fax** +60 4 226 6872

**Genie Japan**

**Phone** +81 3 3453 6082  
**Fax** +81 3 3453 6083

**Genie Korea**

**Phone** +82 2 558 7267  
**Fax** +82 2 558 3910

**Genie Africa**

**Phone** +27 11 455 0373  
**Fax** +27 11 455 0355

**Genie Latin America**

**Phone** +55 11 4055 2499  
**Fax** +55 11 4043 1661

Distributed By: