



110V - 16A

## v2 110V Uplight..

Low energy fluorescent work light

### INTRODUCTION

Defender Uplight is an all-round lighting solution for construction, outdoor event, workshop and domestic DIY use. Self-righting with separate light and base you can lean it, lay it, stand it, hang it and link it – but you can't knock it.

### SPECIFICATION

<b>Voltage</b>	110V~ 50Hz
<b>Plug type</b>	Rewireable BSEN60309
<b>Lamp Type</b>	36W (4ft) Fluorescent 18W (2ft) Fluorescent
<b>Operating Temperature</b>	-20°C ~ 60°C
<b>Cable type</b>	1.5mm, 3 Core H05-VVF VDE
<b>Ingress Protection</b>	IP44
<b>Running Current</b>	<1A
<b>Tested to</b>	BSEN 60598-1:2008 BSEN 60598-2-4:1998

### FEATURES

- High output low energy light source
- Impact and scratch resistant lens
- 16A power outlet for linking multiple units
- Non-slip rubber foot
- Multiple hanging points & detachable shoulder strap
- Ideal for outdoor and indoor use
- IP44 Rated

- ▶ More info
- ▶ Features & benefits
- ▶ Image library
- ▶ Online catalogue
- ▶ Instruction manual

### SIZE & WEIGHT

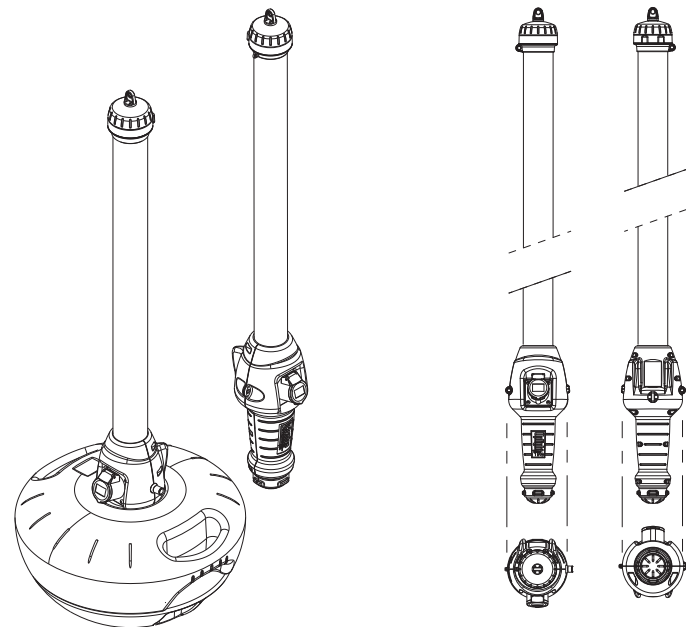

Base dimension: 460 x 275 x 460mm (W x H x D) - Weight 2.58kg  
 Packaging weight 0.47kg - Total packaged weight 3.05kg  
 Product dimension: 163 x 1625 x 163mm (W x H x D) - Weight 2.95kg  
 Packaging weight 1.0kg - Total packaged weight 3.95kg

All information contained in this document is © Defender Power & Light

