

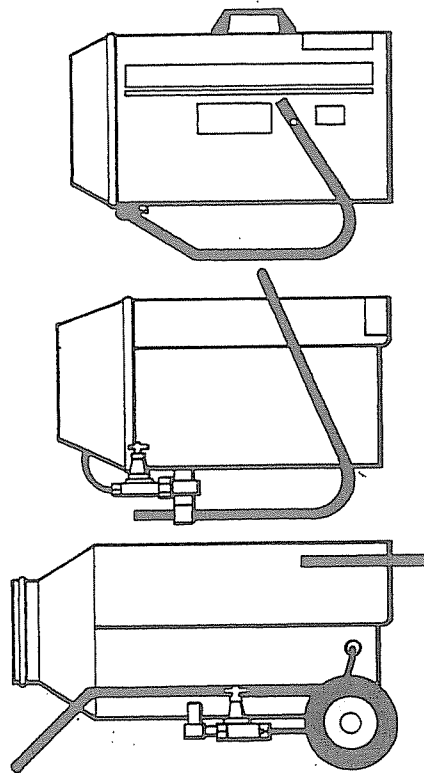

G60DV - G125DV - G260DV



PARTS & MAINTENANCE MANUAL

Part No. 30.48.712/2

Warning

- Type 'A' Appliance.
- This appliance is "not for domestic use". Space Heating only.
- This appliance must not be used in Basements or below ground level.
- Permanent ventilation to the outside atmosphere must be provided.
- Allow (25cm²) for every (1000W) divided equally between floor and high level.
- Allow a maximum heater rating of (100w/m²) of free room space.
- The positioning of the appliance in respect of Fire hazards, in particular that the outlet for products of Combustion shall not be closer than 3 mtrs to any adjacent combustible wall, ceiling or materials.
- Do not restrict inlet and discharge ends of heater.
- Refer to manual for maintenance and fault finding procedure.
- Isolate from electrical supply before commencing maintenance.
- This appliance must be earthed.
- Gas hose should be to BS3212/2 or equivalent and shall not exceed 2 mtrs in length. Avoid any torsional stressing of flexible Gas Hose.

Emergency Action in the event of a Gas Leakage

- Usually detected by a distinctive smell.
- Never look for a leak with a naked flame.
- Close all cylinder valves.
- Extinguish all sources of ignition in vicinity.
- Open all doors and windows.
- If leakage cannot be stopped remove cylinders to a safe place in open air and advise supplier.
- Do not use installation until it has been checked by the gas supplier or other competent person.

Principle of operation

The LPG forced draught heaters are fitted with an atmospheric gas injector burner, LPG from a suitable cylinder is controlled by the pressure regulating valve and supplies the heater through a high pressure gas hose. When the gas relay valve knob is depressed, gas flows to the burner head where it is ignited by the high intensity electric spark from the PIEZO igniter. The safety thermocouple is heated by the flame and feeds a voltage back through the thermocouple lead to the gas relay valve. When this voltage is sufficient, the knob can be released then the burner will continue to run.

The safety gas relay valve will close the gas supply in the event of flame failure and if an overheat condition occurs due to excess gas pressure or low air flow, the overheat thermostat will automatically shut off the flame. A safety solenoid valve is also incorporated which gives an instantaneous shut off in the event of mains electricity failure or the fan being switched off before the burner is shut down.

An axial flow fan provides main airflow which combines with burning gas and air mixture to produce a large volume of heated air.

Operating Instructions

Important LPG Safety.

Use Propane vapour Off-Take Cylinders only. Conversion to other categories of fuel is **not** permitted.

Minimum required.

Model G60DV. 1 x 18kg. Model G125DV 1 x 47kg. Model G260DV 2 x 47kg.

By increasing the number of cylinders running times will be extended. Cylinders can be connected together using pigtail and tee assemblies. To avoid 'Icing' of cylinders in extremely cold weather conditions it will be necessary to increase cylinder quantities to maintain vapour capacity and heater efficiency.

Propane Gas is considerably heavier than air and highly flammable. Never look for a gas leak with a naked flame but trace by smell and confirm by brushing a soap solution over the suspected leak.

A Pressure Regulator and high Pressure Hose are fitted to the heater and before attaching the Regulator to the Propane Cylinder, Ensure mating parts are free from grease and dirt and are undamaged. Fit the Regulator to the cylinder, tightening the LH thread as tight as possible with a Propane spanner 30mm.

To change the cylinder, firstly turn off the Gas supply valve before loosening the LH thread using a propane spanner 30mm. This operation must be carried out in a well ventilated flame-free atmosphere.

Propane cylinders must be used and stored in accordance with "The highly Flammable Liquids and Liquefied Petroleum Gas Regulations 1972" (or current local standards). It is important to avoid torsional stress on the Gas Supply Hose.

Check Gas Hose for damage and verify that the hose shows no sign of cracking.

Use only manufacturers recommended replacement parts.

Electrical Supply

The G60DV - G125DV - G250DV are designed to operate either from a 240v 1PH 50Hz or 110v 1PH 40Hz electrical supply by selecting the required voltage on the slide switch. To change the voltage remove the aluminium switch plate by removing the 2 self tapping screws, move the switch to the required voltage position reverse the plate and screw back into position.

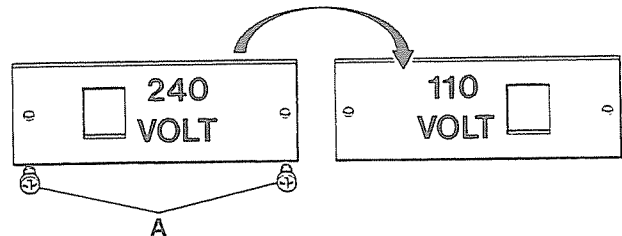

Fit a suitable plug to the flexible mains lead and plug into a 13 amp socket outlet or a suitable 110V supply. Fuse size 5 amp.

THIS APPLIANCE MUST BE EARTHED

Plug must be wired according to the following colour codes.

BROWN — LIVE BLUE — NEUTRAL GREEN/YELLOW — EARTH
IF ANY DOUBT EXISTS REGARDING ELECTRICAL SUPPLY, PLEASE CONSULT YOUR SUPPLIER.

To Start

Switch on electrical supply. Ensure gas regulator is correctly fitted.

Move switch to ON. ENSURE FAN IS ROTATING, then depress pilot valve knob and ignition button to light burner. When burner is lit release ignition button but keep pilot depressed for 30 seconds, then release. Should burner fail to light wait 1 minute then repeat start sequence.

DO NOT HOLD DOWN PILOT VALVE FOR LONGER THAN 30 SECONDS. IF BURNER FAILS TO LIGHT CONTACT SUPPLIER.

Adjust gas regulator to give required heat output.

To Stop

Close cylinder valve but allow fan to run for 5 minutes to cool heater. Move fan switch to OFF and unplug from electrical supply.

To use Heater for ventilation only

Disconnect regulator from gas cylinder.

Move fan switch to ON.

When operation is complete move fan switch to OFF and unplug from electrical supply.

Maintenance (General)

Isolate from Gas and Electrical supplies before any maintenance checks. Keep all external surfaces clean by wiping with a dry cloth. For stubborn marks, light application of a cleaning solvent may be used, do not apply solvents to any electrical devices.

Internal dust can be removed with a compressed air line.

The heater will require an annual service and safety check or more frequently if used in a Dirty/Harsh environment, it is recommended that this service is carried out by a recognised agent and not attempted by untrained persons.

Burner Service G60DV

Disconnect the heater from the electricity supply and from the gas cylinder. Remove the four screws and withdraw fan and burner assembly.

Undo the union nut connecting the jet block, filter and solenoid assembly to the gas relay valve, remove the spring clip from the jet block and withdraw the gas control assembly. Check the Amal jet and blow in the opposite direction to the gas flow to remove any obstruction. Re-make any threaded joints using Calortite.

Clean flame parts and internal perforated mesh using an air line then brush off any remaining particles of hair or dust.

Check electrode by wiping clean and checking for cracks and tightness and see if setting of electrode and thermocouple are correct.

NB! Thermocouple must be pushed in as far as possible and be in line with burner flame parts.

Burner Service G60DV cont.

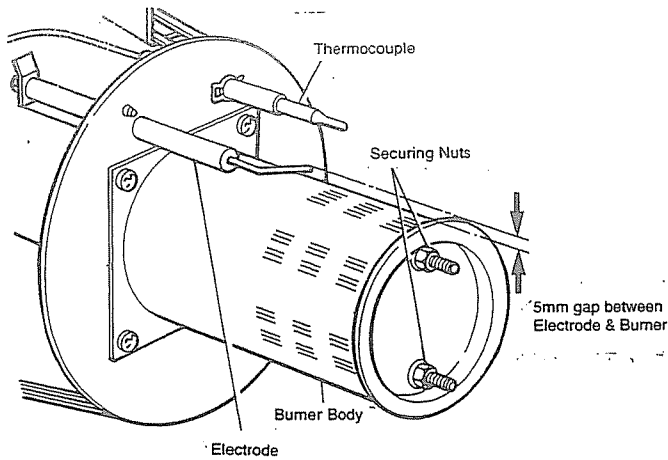

Burner Service G125DV/G260DV

Remove jet body retaining clip, deflector plate screw and three wing nuts securing burner. The electrode/bracket assembly and thermocouple will also be freed and can be removed. Withdraw burner from outlet end of combustion chamber. Clean between the flat and corrugated rings using an air line then brush off any remaining particles of hair or dust. Undo the union nut connecting the jet block, filter and solenoid assembly to the gas relay valve, remove the spring clip from the jet block and withdraw the gas control assembly. Check the Amal jet and blow in opposite direction to the gas flow to remove any obstruction. Note that an in-line filter is fitted before the solenoid valve, this unit should not require attention but should it be suspect eg. too little heat output at maximum rate, the filter must be replaced. Remake any threaded joint using Calorite. Clean ignition electrode, check ceramic is in sound condition and examine thermocouple for signs of oxidation. Reassemble burner as shown below ensuring that correct electrode gap is maintained.
NB! Thermocouple must be pushed in as far as possible.

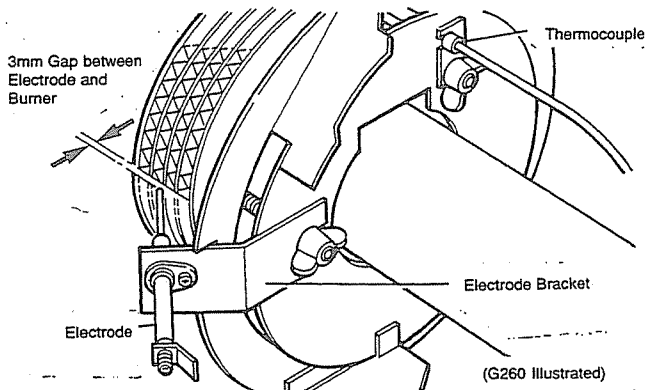

Gas Supply

Check tightness of joints on high pressure supply hose and check pipe connection. LPG has a distinctive smell and leaks can usually be detected immediately by this fact. If a leak is suspected extinguish all naked lights and close cylinder valve.

NEVER look for a leak with a naked flame but trace by smell and confirm by brushing a soap solution over the suspected leak.

Electrical

Check that motor fixing bolts are tight and also make sure that the fan fixing screw at the fan boss is tight. Remove control cover and check that all connections are tight.

The overheat thermostat and thermocouple junction should be checked to ensure continuity. This circuit is not connected to the mains supply and relies on the small current generated by the thermocouple to energise the pilot relay, any loose joints could cause a high resistance and prevent the safety relay from holding in, thus shutting down the burner.

General

Clean heater body inside and out, re-assemble heater making sure all screws and fixings are tight.

Re-connect to mains electrical and propane supply and start and test as described in previous pages.

Ensure all operating instruction and warning labels are affixed and legible.

Storage

When not in use the heater should be stored in a clean dry place protected from accidental damage.

Gas Hose Regulator assembly should be protected from contact with direct sun light, as this can cause premature deterioration of the Gas Hose.

Fault Finding

ISOLATE FROM ELECTRICAL SUPPLY BEFORE REMOVING CASING OR CONTROL PANEL COVER.

FAULT	ACTION
MOTOR FAILS TO START	(a) Check that an electrical supply is present at the heater using a mains tester. (b) Check fan switch is operating. (c) Check push on connector and terminals are tight. (d) Check that the motor runs freely. (e) Replace faulty parts.

NO IGNITION

The ignition spark is provided by a piezo ignitor, if there is no spark when the ignition button is pushed.

- Check electrode for cracks and correct gap.
- Check H.T. Lead and H.T. connections.
- Replace ignitor or faulty parts.

NO GAS AT BURNER

The gas supply from this relay valve to the burner injector is controlled by the safety solenoid shut off valve. Replace only with an approved replacement part.

- Check cylinder valve is open.
- Check cylinder contains gas.
- Check regulator setting.
- Check that hose and unions are tight. (Use a soap solution to search for leaks, NEVER USE A NAKED FLAME!)
- Check injector for blockage.
- Check solenoid valve operation.
- Check gas filter for blockage.
- Replace faulty parts.

BURNER FAILS TO IGNITE

BURNER STARTS BUT GOES OUT WHEN GAS RELAY VALVE IS RELEASED

- Check 1-3.
- Check electrode location.
- Check tightness of thermocouple connection into the relay valve. (N.B. screw in finger tight then give an extra 1/4 turn with a spanner).
- Check electrical continuity through thermocouple and overheat thermostat circuit.
- Replace faulty parts.

WIRING DIAGRAMS

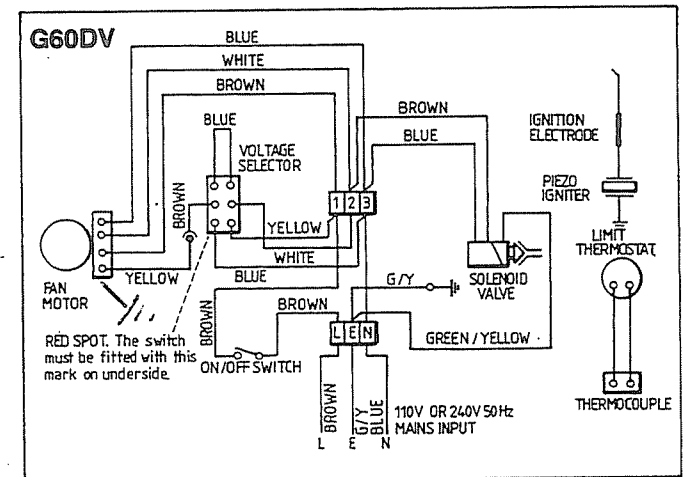

WIRING DIAGRAMS cont.

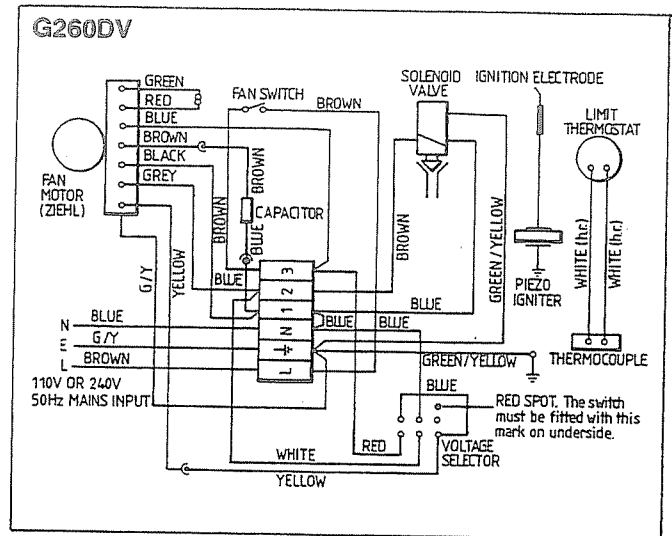
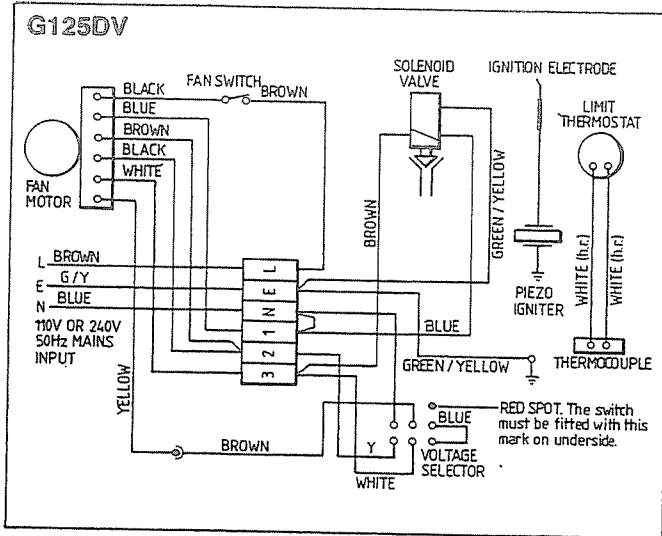

Technical Specification

	G60		G125		G260	
	Metric	Imperial	Metric	Imperial	Metric	Imperial
Heat Input	4.39 KW 17.58	15,000 Btu/h 60,000	8.8 KW 36.63	30,000 Btu/h 124,981	19 KW 76.18	65,000 Btu/h 260,000
Fuel Supply	Propane Vapour					
Gas Pressure	.06 - 1 bar .9 - 15 psi					
Fuel Consumption	.32 kg/h 1.26	.67 lbs/h 2.79	.63 Kg/h 2.4	1.39 lbs/h 5.3	1.36 Kg/h 5.5	3 lbs/h 12.13
Injector	1.02mm		1.4mm		2.25mm	
Approx Heated Area	425m ³	15,000ft ³	858m ³	31,250ft ³	1840m ³	65,000ft ³
Air Flow	.117m ³ /s	250cfm	.19m ³ /s	400cfm	.57m ³ /s	1200cfm
Motor Speed	1340 rpm		1425 rpm		1400 rpm	
Electrical Supply	230 Volts 1 PH. 50HZ or 110 Volts 1PH 50HZ					
Running Current	.3A(230v) .6A(110v)		.4A(230v) .8A(110v)		.76A(230v) 1.4A(110v)	
Fuse Size	2A		5A		5A	

Parts Illustrations

G60DV

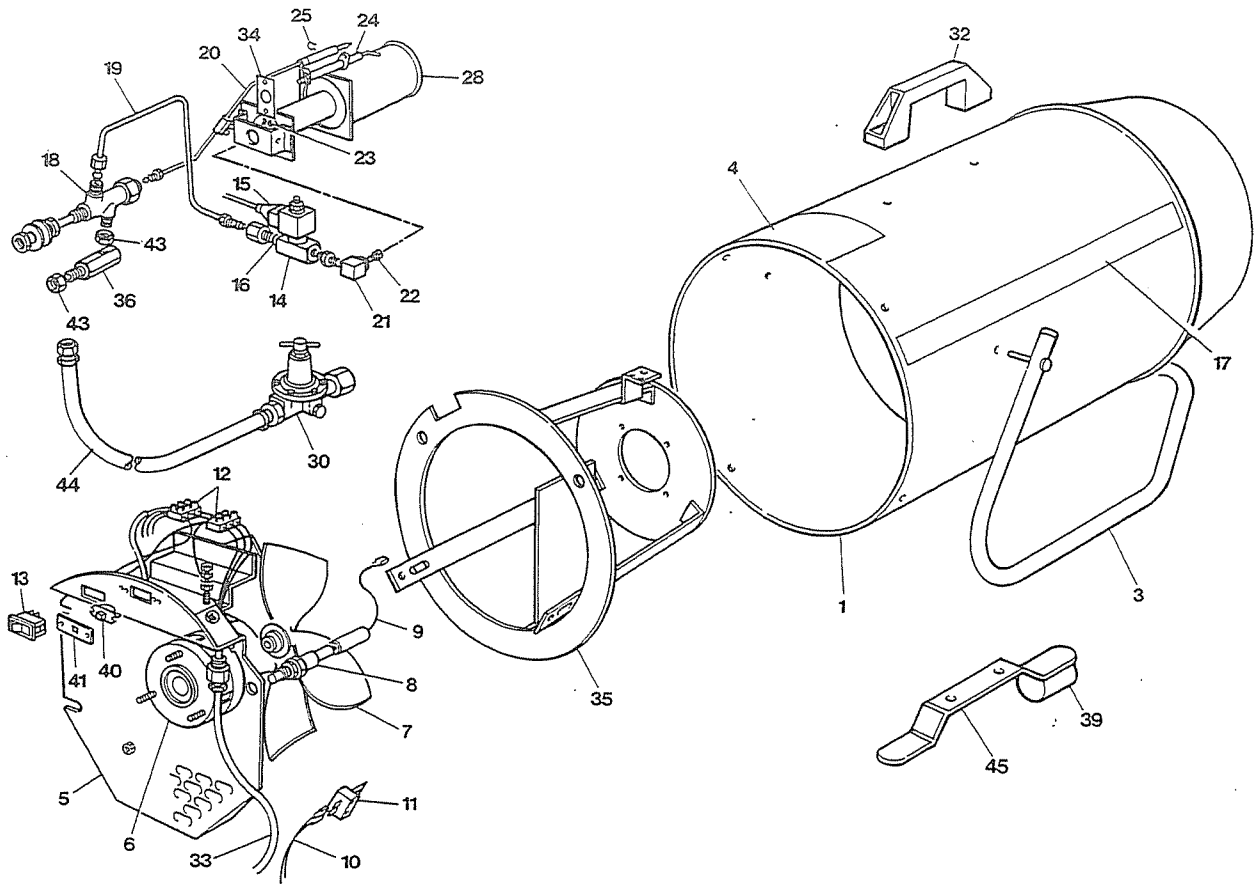

G125DV

