



*PUSH 6 Eco*  
**Elevating Work Platform**

Operator's Safety and Maintenance Handbook

PN 510843-000-EN  
SEP 2011 SN 4223+



# POP-UP PUSH 6 ECO

## Operator's Safety and Maintenance Handbook

### Contents

Section 1	Page	Section 5	Page
<b>DESCRIPTION</b>		<b>MAINTENANCE</b>	
Introduction	3	Safety during maintenance	13
Description	3	Periodical maintenance and checks	13/14
Intended use	3	Storage	14
Training	3	Lubrication	14
Modifications	3	Hydraulic oil	15
Terminology	5	Electrical schematic	16
		Hydraulic schematic	17
		Troubleshooting	18
<b>Section 2</b>		<b>Section 6</b>	
<b>SPECIFICATION</b>		<b>TRANSPORT INSTRUCTIONS</b>	
Technical data	6	Loading and unloading	19
Operating site	7	Lifting	20
Noise and vibration	7	Preparation for transport	20
Limitations	7		
<b>Section 3</b>		<b>Section 7</b>	
<b>SAFETY RULES</b>		<b>MAINTENANCE AND REPAIR RECORD</b>	
Safety Rules	8	Maintenance and repair record	21
		Notes	22
<b>Section 4</b>		Daily checks – operator checklist	23
<b>OPERATING INSTRUCTIONS</b>			
Daily checks	9		
Manoeuvring the platform	9		
Engaging the brakes	10		
Powering up	10		
Entering and leaving the platform	11		
Control pendant	11		
Emergency stop	12		
Emergency lowering	12		
Battery charging	12		

## Introduction

This handbook provides information on the safe operation of this work platform. Operators should read and understand all of the information contained within this manual prior to operating the work platform.

An abridged set of instructions in the form of a training card and a training sticker can also be found attached to the **POP-UP PUSH 6 ECO** at the control pendant and toe board respectively.

The handbook contains several warnings, these indicate situations which if not avoided could result in serious injury or death to persons, or damage to the machine or property.

Additional copies of this handbook are available from the manufacturer at the address below. Information contained in this handbook is based on the latest product information at time of publication.

**POP-UP Products Ltd** operate a policy of continuous improvement and therefore reserve the right to make product changes at any time without obligation.

## Description

The **POP-UP PUSH 6 ECO** is a scissor lift type work platform, which is manoeuvred manually into work positions and elevated and lowered using an electro-hydraulic control system.

The standard machine includes the following standard features:

- **240kg safe working load**
- **3.63 metre working height**
- **1.65 metre stowed height**
- **Easily manoeuvrable**
- **Weights just 225kg**
- **Pass through standard doors**
- **Simple operation**
- **Steel guard rails**
- **Non-slip platform**
- **Steerable wheels**
- **Brakes on two wheels**
- **Battery powered with built-in battery charger**
- **Emergency lowering facility**
- **Easily transportable**
- **Low maintenance**
- **Complies with EN280:2001**

## Intended use

The machine has been designed to comply with the safety requirements of the Machinery Directive 98/37/EC taking guidance from the European Standard EN280:2001 Mobile Elevating Work Platforms.

The machine is intended to be used to lift persons, plus essential tools and materials, to enable work to be undertaken at height. Typical applications will include maintenance, cleaning, painting, etc. at varying heights above ground level.

### **WARNING**

**THE MACHINE MUST NOT BE USED IN APPLICATIONS OR FOR USES OUTSIDE OF THE SCOPE OF THIS HANDBOOK. SHOULD A CERTAIN APPLICATION NOT BE COVERED, THEN THE MANUFACTURER SHOULD BE CONTACTED**

# Training

Since **POP-UP PUSH 6 ECO** is classed as 'work equipment' it also falls within the scope of the Provision and Use of Work Equipment Regulations 1998 (PUWER). Regulation 9 of PUWER requires that persons using this equipment have received adequate training.

A full Operator's Safety & Maintenance handbook is provided with the equipment which forms the basis of training on and familiarisation of the equipment. Safety decals are also fitted to the machine to warn the operator and other personnel of potential hazards whilst the machine is in use.

## **WARNING**

**OPERATION OF THIS MACHINE BY UNTRAINED OPERATORS MAY RESULT IN SERIOUS INJURY OR DEATH**

# Modifications

No modifications must be made to this machine unless the manufacturer has given full written approval. If in doubt contact the manufacturer for advice.

Manufacturer's address:

## **POP-UP**

**Vigo Centre  
Birtley Road  
Washington  
Tyne & Wear  
NE38 9DA  
UK**

**Tel +44 (0)845 1550 057  
Fax +44 (0)845 1557 756**

# Terminology

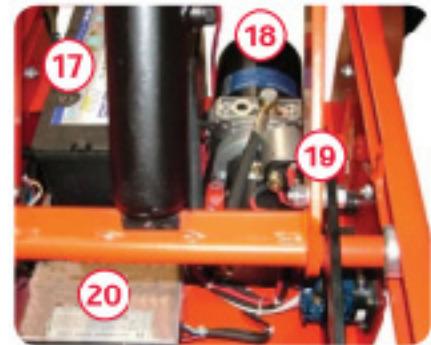

- |                               |                             |                                     |
|-------------------------------|-----------------------------|-------------------------------------|
| 1 Control pendant             | 10 Main lift cylinder       | 19 Hydraulic Pack                   |
| 2 Emergency stop button & key | 11 Maintenance props        | 20 Battery charger                  |
| 3 Training card               | 12 Winch point              | 21 Chassis plate                    |
| 4 Guard rail                  | 13 Forklift pocket (1 of 4) | 22 Battery charger socket           |
| 5 Gate                        | 14 Chassis                  | 23 Battery charging indicator       |
| 6 Handbook                    | 15 Bubble spirit level      | 24 Battery condition meter & button |
| 7 Platform                    | 16 Brake (1 of 2)           | 25 Maintenance Isolator switch      |
| 8 110V and 240V charger leads | 17 Battery                  | 26 Warning buzzer                   |
| 9 Scissor pack                | 18 Hydraulic tank           | 27 Emergency lowering valve         |

## Technical data

Safe working load (SWL) equivalent to	240kg 1 person + 160kg tools and materials
Maximum platform height Maximum working height	1.63 metres 3.63 metres
Platform length Platform width Platform guard rail height Toe board height	1.01 metres 0.52 metres 1.10 metres 0.15 metres
Maximum allowable manual force Maximum allowable wind speed Maximum allowable chassis inclination	200 Newtons 0 metres/sec 0 degrees
Electrical system Motor Batteries Battery charger	12 volt DC 0.7 kW 1 x 80 Ah Self-seeking automatic range 90 – 240 volt AC
Hydraulic system Maximum pressure Reservoir capacity	 250 bar 1 litre
Function speeds (approx.) Raise Lower Approx. no. of lifts (fully charged with SWL)	 8 seconds 7 seconds 300
Overall length (stowed) Overall height (stowed) Overall width (stowed)	1.2 metres 1.65 metres 0.70 metres
Overall mass (GVW) Maximum wheel load	225kg 350kg

## Operating site

Select a site for the machine from which the platform will be able to reach the required work area. A visual inspection of the operating site should be made before setting up the machine. Particular attention should be given to the following items:

### 1. Ground conditions

Ensure that the ground on which the **POP-UP PUSH 6 ECO** is to operate is capable of supporting the weight of the machine (including the weight of the operator plus tools and materials). Be aware of floors or coverings (e.g. manhole covers) that may not withstand point loadings exerted by the castor wheels.

### 2. Ground flatness

The **POP-UP PUSH 6 ECO** must only be operated on flat (0° chassis inclination) and level surfaces. The allowable chassis inclination is indicated when the bubble spirit level is within the marked limits. All castor wheels must be in full contact with the ground.

### 3. Overhead obstructions

Ensure that adequate clearance is available above and around the platform before elevation.

## Noise and vibration

Noise levels emitted from this machine do not exceed 70 dB(A). Hand and arm vibration experienced on this machine does not exceed 2.5 m/s<sup>2</sup>.

## Limitations

The **POP-UP PUSH 6 ECO** is intended for use **INDOORS ONLY**, and must not be used outdoors as wind forces may make it unstable.

This machine has been tested for Electromagnetic Compatibility (EMC) however, operation near to high powered radio transmission apparatus (e.g. radar, antennae) or within strong electrical and/or magnetic fields may affect some features of this product.

### **WARNING**

**THIS MACHINE HAS NOT BEEN DESIGNED FOR OPERATION WITHIN POTENTIALLY EXPLOSIVE ATMOSPHERES**

### **WARNING**

**THIS MACHINE IS NOT ELECTRICALLY INSULATED AND MUST NEVER BE USED FOR LIVE LINE WORKING. DEATH OR SERIOUS INJURY CAN RESULT FROM CONTACT WITH, OR INADEQUATE CLEARANCE FROM, ELECTRICAL CONDUCTORS**



# Safety Rules

- NEVER** Exceed the rated capacity (Safe Working Load or SWL) of the platform (240kgs).
- NEVER** Use the **POP-UP PUSH 6 ECO** as a 'crane' (e.g. by suspending loads from beneath the platform).
- NEVER** Make any attempt to increase the working height or outreach of the platform (e.g. by use of stepladders in the platform).
- NEVER** Operate the **POP-UP PUSH 6 ECO** if the bubble spirit level is outside the marked limits.
- NEVER** Manoeuvre the **POP-UP PUSH 6 ECO** on an inclined surface otherwise it may become uncontrollable.
- NEVER** Manoeuvre the **POP-UP PUSH 6 ECO** whilst in its elevated position, as this may cause instability.
- NEVER** Manoeuvre the **POP-UP PUSH 6 ECO** with a person or materials in the platform.
- NEVER** Enter or exit the platform unless the platform is in the lowered and transport position.
- NEVER** Apply external side loads to the platform or scissor structure.
- NEVER** Allow persons at ground level to operate the controls whilst the platform is occupied (unless in an emergency situation).
- NEVER** Operate the **POP-UP PUSH 6 ECO** outdoors, it has not been designed to withstand wind loading.
- ALWAYS** Undertake the daily checks recommended in this handbook p.9 prior to operation of the machine.
- ALWAYS** Ensure that all instructions, Safe Working Load and warning decals are clean and legible.
- ALWAYS** Ensure the **POP-UP PUSH 6 ECO** is positioned on adequate ground to support the weight of the machine.
- ALWAYS** Ensure that sufficient clearance is given if working near to live conductors.
- ALWAYS** Ensure that the castor brakes have been locked before elevating the work platform.
- ALWAYS** Ensure that the platform does not come into contact with fixed objects (e.g. buildings, etc.) or moving objects (e.g. vehicles, other plant equipment, etc.).
- ALWAYS** Replace any removable guard rails (e.g. close and lock access gate) to enable full edge protection to be maintained.
- ALWAYS** Ensure that the load is evenly distributed within the platform.
- ALWAYS** Ensure the safety of persons that may enter the area around the platform (e.g. cordon off areas to prevent persons entering the danger area).
- ALWAYS** Ensure hands are kept within the confines of the handrail when operating the machine.
- ALWAYS** Ensure that the area below the platform is clear of obstruction before lowering.

## Daily checks

Prior to operating the **POP-UP PUSH 6 ECO**, the following items must be checked:

- **Structure** (e.g. damage, cracks, corrosion, abrasion, welds, connections)
- **Platform** (floor, rails, handrail sockets)
- **Castors** (smooth movement, damage)
- **Brakes**
- **Oil leaks**
- **Battery condition**
- **Raise and lower functions**
- **Emergency stop and lowering functions**
- **Safety decals and training card**

If the above checks reveal malfunctions or damage on the **POP-UP PUSH 6 ECO**, then the machine must not be used until the problem is rectified.

If in doubt, seek further assistance from the manufacturer.

If safety decals are no longer legible or missing, please contact the manufacturer for replacements.

The Daily Checks page in Section 7 of this handbook may be photocopied to provide an aide memoir for operators when undertaking these important checks.

### **WARNING**

**BEFORE OPERATING YOUR POP-UP PUSH 6 ECO, YOU MUST ENSURE THAT YOU HAVE BEEN ADEQUATELY TRAINED IN ITS USE AND HAVE FULLY READ AND UNDERSTOOD THIS OPERATOR'S HANDBOOK, PAYING PARTICULAR ATTENTION TO SECTION 3 - SAFETY RULES**

## Manoeuvring the platform

Manoeuvre the platform into position using both hands on the guard rails at gate end. Take care to avoid trapping hands or feet whilst manoeuvring the platform.

Never manoeuvre the **POP-UP PUSH 6 ECO** whilst it is elevated or with a person, tools or materials in the platform.



## Engaging the brakes

Always ensure that both castor brakes are locked before elevating the work platform to prevent any inadvertent movement.

The brakes are engaged by pushing down on the lever and pulling up the lever as shown.



Brake off



Brake on

## Powering up

The **POP-UP PUSH 6 ECO** is provided with a key operated switch which is used to isolate the battery and therefore the electrical system, preventing unauthorised use. To enable the electrical system, first turn the Maintenance Isolator switch to position '1' (**ON**) and insert the key into the emergency stop button. Turn clockwise to release the button. Ensure that when the machine is not in use, the emergency stop button is depressed and the key is removed. Turn the Maintenance Isolator switch to position '0' (**OFF**).



## Entering and leaving the work platform

Always use three points of contact when entering or exiting the platform, using the guard rails provided. For example, use two hands and one foot, as shown below. Use the step provided on the base of the machine.

On entering the platform, ensure that the gate is closed behind you.



## Control pendant

The control pendant houses the platform raise and lower controls.

**Pressing the enable button and selecting 'UP' raises the platform.**

**Pressing the enable button and selecting 'DOWN' lowers the platform.**

Take care to avoid repeated jerky movements which could cause unnecessary impact loads on the structure.





## Emergency stop

An emergency stop button is provided on the control pendant. Once depressed, this isolates power to the raise and lower functions.

To restore functionality, twist the emergency stop button clockwise to release the button, as shown below.

Turning the Maintenance Isolator switch to the '0' position also has the effect of isolating power to the raise and lower functions.



## Emergency lowering

To lower the platform in the event of an emergency, a control is provided at the chassis.

Turning the knob in an ANTICLOCKWISE direction, as shown, opens the lift valve. Once the valve is fully open the platform will lower, at this point please stand back to ensure your safety. Always close the valve after use.



## Battery charging

A battery condition meter is fitted to the **POP-UP PUSH 6 ECO** as shown. To check the battery condition, elevate the platform from ground level whilst at the same time pressing the red button above the battery condition meter. This is the only way to obtain an accurate reading. The battery will require charging if there is less than 4 bars on the display. Do not attempt to use the machine in this state as battery damage may occur. Never allow the battery to run completely flat as this damages the cells and can lead to premature battery failure. It is good practice to charge the battery daily to ensure optimum battery condition. The **POP-UP PUSH 6 ECO** is supplied with a built-in multi voltage automatic battery charger, for supply voltages between 90V and 240V AC. The battery charger is located on the underside of the platform.



### To charge the battery, follow these steps:

1. Turn the Maintenance Isolator switch to '0' (OFF) position.
2. Connect the battery charger lead to the **POP-UP PUSH 6 ECO** at the point shown.
3. Connect the battery charger to the power supply (either 110V or 240V AC at 50 Hz depending on the mains supply).
4. Turn the Maintenance Isolator switch to '2' (CHARGE) position.
5. The battery should be fully recharged once the 95% LED is illuminated on the charging indicator.



## Safety during maintenance

When performing maintenance on the **POP-UP PUSH 6 ECO** with the platform elevated, always ensure that the maintenance props are engaged as shown.



**WARNING**

FAILURE TO ENGAGE THE MAINTENANCE PROPS MAY RESULT IN THE PLATFORM LOWERING WITHOUT WARNING

## Periodical maintenance and checks

The following checks should be undertaken at the recommended intervals shown:

	Daily/Pre-use	Monthly	6 Monthly	12 Monthly
Inspect structure	●	●	●	●
Inspect platform	●	●	●	●
Check castors	●	●	●	●
Check brake function	●	●	●	●
Inspect for oil leaks	●	●	●	●
Check battery condition	●	●	●	●
Check raise/lower functions	●	●	●	●
Inspect training card and safety decals	●	●	●	●
Check hydraulic oil level		●	●	●
Inspect limit switches		●	●	●
Inspect wiring		●	●	●
Check electrical connectors		●	●	●
Lubricate roller guides		●	●	●
Lubricate grease nipples		●	●	●
Lubricate pivot pins			●	●
Lubricate castor mounts			●	●
Replace hydraulic oil				●

## **Periodical maintenance and checks (continued)**

Prior to first use of the **POP-UP PUSH 6 ECO**, all daily/pre-use checks must be undertaken. If the machine has been in storage for a long period of time, it may be necessary to undertake checks and tests as per the table on the preceding page (e.g. lubrication, hydraulic oil, battery condition).

The Lifting Operations and Lifting Equipment Regulations 1998 (LOLER) require that lifting equipment for lifting persons must be THOROUGHLY EXAMINED every six months.

Following any maintenance on the **POP-UP PUSH 6 ECO**, a full function test should be undertaken to ensure correct operation of the machine.

It is essential that only manufacturer's approved replacement parts are used when maintaining and servicing the **POP-UP PUSH 6 ECO**.

Failure to do so may result in an unsafe or unstable machine.

## **Storage**

The electrical components of this **POP-UP PUSH 6 ECO** are not protected from external weather conditions and the machine should therefore not be stored outdoors. Storage in a clean, dry indoor environment is recommended.

Frequent checks on the condition of the machine should be made to ensure no excessive deterioration occurs due to the environment in which the machine is housed.

## **Lubrication**

The required lubrication points are listed as per the table on the preceding page. These include: roller guides, grease nipples, pivot pins and castor mounts.

The lubricant recommended for use with this **POP-UP PUSH 6 ECO** is: standard machine grease.

# Hydraulic oil

The hydraulic oil level can be checked by removing the filler cap fitted to the hydraulic oil tank shown below. The correct amount of oil is in the tank when hydraulic fluid appears on the tip of the dipstick. This check must be carried out with the platform in the fully lowered position.

The hydraulic oil can be topped up by adding oil to the filler as highlighted below. Take care not to spill hydraulic fluid over any of the surrounding machine components.

The hydraulic oil can be drained by removing the tank. Remove the 4 bolts as highlighted below and separate the tank from the pump body. The hydraulic fluid can then be correctly disposed of. Reassembly is the reverse of above.

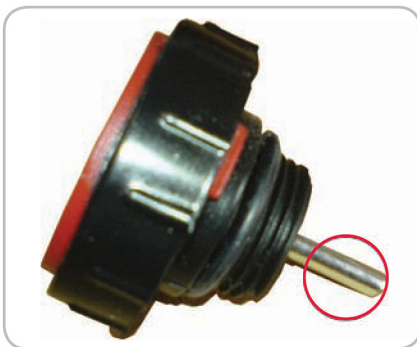

Filler cap/dipstick



Oil filler



Bolts

The hydraulic oil recommended for use with this **POP-UP PUSH 6 ECO** is:

mineral basis hydraulic oil with lubricating, antifoaming, anti-corrosive, antioxidant HL-HLP (ISO and UNI HM)-HV-HLPD performances according to DIN51524 part 1-2 standards

<b>Minimum viscosity</b>	<b>15cts (23°E / 77,39 SSU at 100°F)</b>
<b>Max. viscosity at starting up</b>	<b>800cts (105,6°E / 3708 SSU at 100°F)</b>
<b>Max. working viscosity</b>	<b>100cts (13,2 E / 463,5 SSU at 100°F)</b>
<b>Suggested viscosity range</b>	<b>25 ÷ 40 cts = (3,47 ÷ 5,35° E / 119,3 ÷ 186,3 SSU a 100°F)</b>
<b>Allowed temperature</b>	<b>Max 80°C (176°F)</b>
<b>Recommended temperature</b>	<b>30 ÷ 60°C (86 ÷ 140°F)</b>



# Electrical schematic

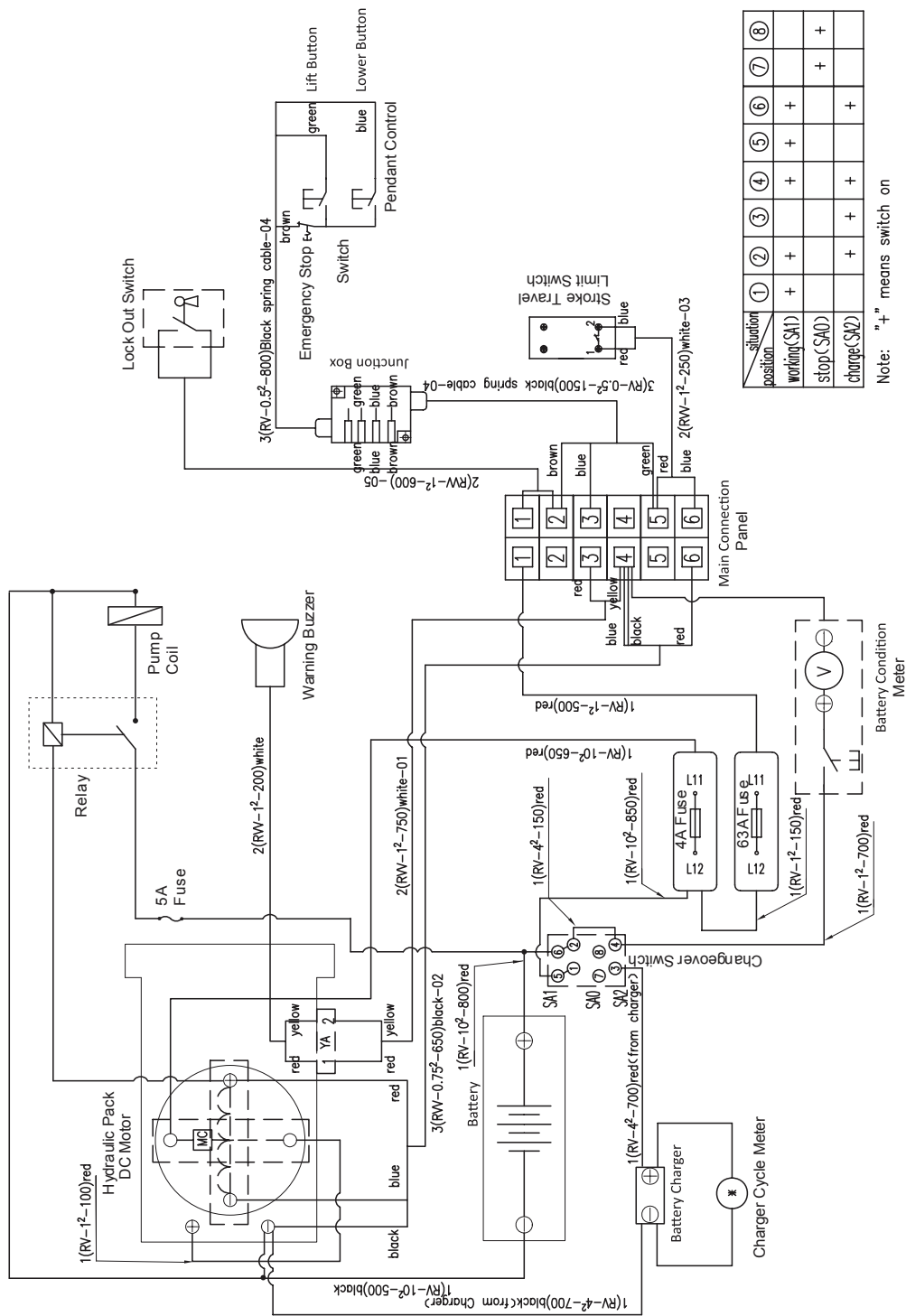

position	①	②	③	④	⑤	⑥	⑦	⑧
working (SA1)	+			+	+	+		
stop (SA0)		+					+	+
charge (SA2)			+	+				

Note: "+, " means switch on

# Hydraulic schematic

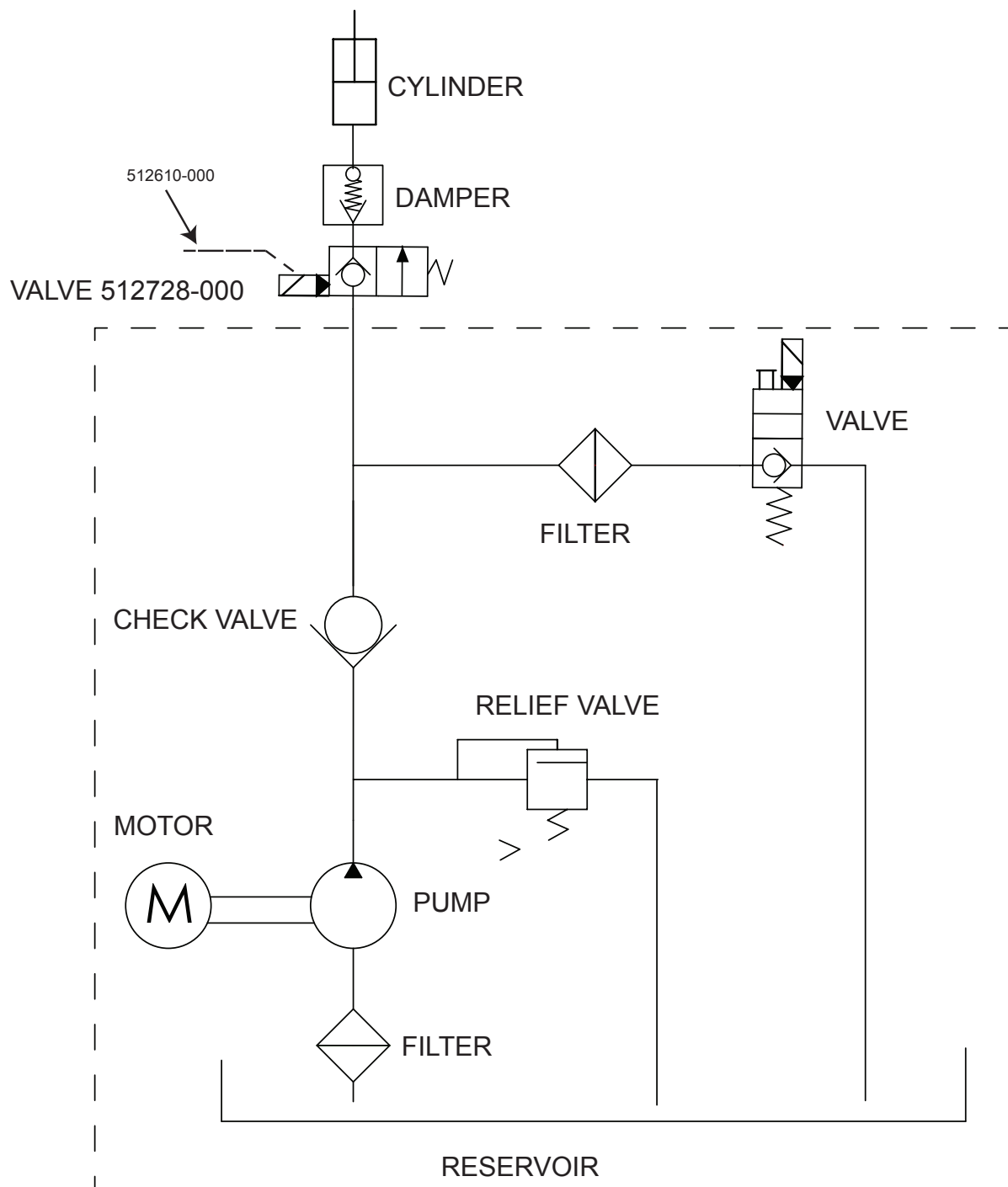

HYDRAULIC CIRCUIT

# Troubleshooting

<b>Problem</b>	<b>Cause</b>	<b>Repair</b>
<b>Platform does not raise (hydraulic pack motor not running)</b>	1. Faulty wiring	1. Check the wiring by referring to the electrical schematic diagram p.16
	2. Battery is disconnected	2. Reconnect the battery
	3. Battery charge is insufficient	3. Charge the battery
<b>Platform does not raise (hydraulic pack motor running)</b>	1. Faulty adjustment of relief valve	1. Adjust relief valve
	2. Faulty hydraulic pump	2. Replace power pack
	3. Insufficient hydraulic oil	3. Add hydraulic oil
<b>Platform creeps (uncontrolled lowering)</b>	1. Oil leakage in power pack	1. Replace lowering valve
	2. Oil leakage from hydraulic circuit	2. Check hydraulic circuit and repair
<b>Oil leakage from cylinder</b>	Faulty sealing	Replace sealing
<b>Oil leakage from hydraulic pipes</b>	Insufficient tightening or seal invalid	Tighten joint again or replace seal
<b>Oil leakage from air breather ( filler cap)</b>	Excessive quantity of oil	Reduce oil quantity

# Loading and unloading

When loading or unloading the **POP-UP PUSH 6 ECO**, use one of the methods



Forklift



Tail lift

shown.

When using a forklift to lift the **POP-UP PUSH 6 ECO**, ensure the forks are sufficiently inserted into the forklift pockets in the base of the machine. Please see the location of the forklift pockets below.

When using a tail lift to load or unload the **POP-UP PUSH 6 ECO** ensure that brakes are applied to **both** castors. Ensure that the capacity of the tail lift is sufficient to handle the **POP-UP PUSH 6 ECO**. Take care when manoeuvring the machine on the tail lift.



Fork lift pocket



Winch point

When winching the machine onto or off a vehicle, ensure that the winch is connected to the winch point as shown below. Ensure personnel are available to guide the machine whilst the winch is in operation.

## WARNING

NEVER ATTEMPT TO LOAD OR UNLOAD THE **POP-UP PUSH 6 ECO** BY MANUAL EFFORT ONLY, SERIOUS INJURY, MACHINE OR PROPERTY DAMAGE COULD RESULT

## Lifting

No lifting attachment points are provided on the **POP-UP PUSH 6 ECO** and therefore lifting of the machine (e.g. with a crane or straps) is prohibited. If lifting of the machine is required, please contact the manufacturer for further details.

## Preparation for transport

Prior to transporting the **POP-UP PUSH 6 ECO** on a vehicle, ensure that the following precautions are taken in order to avoid damage to the machine or damage to the transporting vehicle.

1. Ensure that the platform is fully lowered to its rest position.
2. Ensure that the control pendant is in its cradle.
3. Ensure brakes are engaged on both castors.
4. Secure the **POP-UP PUSH 6 ECO** to the transport vehicle using straps through the forklift pockets as shown below.



## Maintenance

Date	Scheduled maintenance undertaken	By

## Repairs

Date	Repairs undertaken	By

## Examinations/tests

Date	Examinations/tests undertaken	By

PLEASE PHOTOCOPY THIS PAGE FOR YOUR OWN USE, AS REQUIRED.

# Notes

At **POP-UP Products** we welcome any feedback and suggested improvements for our product. Please email us at **feedback@popupproducts.co.uk**

## Daily checks – operator checklist

The following checklist has been provided to enable daily checks to be undertaken prior to use of this **POP-UP PUSH 6 ECO**. These checks should be carried out each working day or at the beginning of each shift. The purpose of the checks is to identify any wear and tear or malfunction of the machine's components and systems.

**WARNING**

FAILURE TO UNDERTAKE THESE CHECKS MAY RESULT IN DEFECTS ON, OR DETERIORATION OF THIS **POP-UP PUSH 6 ECO** GOING UNDETECTED AND POSSIBLY RESULTING IN AN UNSAFE MACHINE

<b>Machine number</b>	
-----------------------	--

Note that Regulation 8 of the Lifting Operations and Lifting Equipment Regulations 1998 (LOLER) require that persons using lifting equipment have appropriate training and instructions to enable them to identify whether lifting equipment is safe to use.

1. Prior to operating the platform, the following items must be checked:  
(please refer to the relevant sections in this handbook for more detail.)

OK? (please tick)	OK? (please tick)
Structure	Battery condition
Platform	Raise and lower
Castors	Emergency stop
Brakes	Emergency lower
Oil leaks	Safety decals and training card

Date \_\_\_\_\_

Checked by \_\_\_\_\_

2. Use raise, lower and emergency stop functions to ensure correct operation.

Should any defects be identified in any of the above areas, these should be reported to your supervisor or employer. It may be necessary to seek further assistance from the supplier of the machine, this may be the hire company or the manufacturer.

You should only rectify any defects if you are authorised and competent to do so.

**Do not use the machine unless each of the items above is checked and stated OK.**





**POP-UP**

**Vigo Centre  
Birtley Road  
Washington  
Tyne & Wear  
NE38 9DA  
UK**

**Tel +44 (0)845 1550 057  
Fax +44 (0)845 1557 756**



ISO9001 : 2008  
Certificate No.FM 513133

