

Specifications

Models	Z-45/25 DC & Bi		Z-45/25J DC & Bi	
Measurements	Metric	US	Metric	US
Working height maximum*	15.87 m	51 ft 6 in	15.94 m	51 ft 9 in
Platform height maximum	13.87 m	45 ft 6 in	13.94 m	45 ft 9 in
Horizontal reach maximum	7.62 m	25 ft	7.65 m	25 ft 1 in
Up and over clearance maximum	7.04 m	23 ft 1 in	7.04 m	23 ft 1 in
A Platform length	0.76 m	2 ft 6 in	0.76 m	2 ft 6 in
B Platform width	1.83 m	6 ft	1.83 m	6 ft
C Height - stowed	2.00 m	6 ft 7 in	2.00 m	6 ft 7 in
D Length - stowed	5.56 m	18 ft 3 in	6.83 m	22 ft 5 in
E Width	1.79 m	5 ft 10.3 in	1.79 m	5 ft 10.3 in
F Wheelbase	2.03 m	6 ft 8 in	2.03 m	6 ft 8 in
G Ground clearance - center	0.24 m	9.5 in	0.24 m	9.5 in

Productivity

Lift capacity	227 kg	500 lbs	227 kg	500 lbs
Platform rotation	180°	180°	160°	160°
Vertical jib rotation	—	—	135°	135°
Turntable rotation	355° non-continuous		355° non-continuous	
Turntable tailswing	zero	zero	zero	zero
Drive speed - stowed	4.8 km/h	3.0 mph	4.8 km/h	3.0 mph
Drive speed - raised**	1.0 km/h	0.61 mph	1.0 km/h	0.61 mph
Gradeability - stowed***	30%	30%	30%	30%
Turning radius - inside	1.83 m	6 ft	1.83 m	6 ft
Turning radius - outside	4.27 m	14 ft	4.27 m	14 ft
Controls	24V DC proportional		24V DC proportional	
Tyres	23 x 37 cm	9 x 14.5 in	23 x 37 cm	9 x 14.5 in

Power

Power source - DC	48V DC (eight 6 V batteries, 350 Ah capacity)			
Power source - Bi-Energy	48V DC (eight 6 V batteries, 350 Ah capacity) with Tier IV Kubota 9.9 kW (13.3 hp) diesel driven alternator			
Auxiliary power unit	24V DC		24V DC	
Hydraulic tank capacity	30.3 L	8 gal	30.3 L	8 gal
Fuel tank capacity- Bi-Energy	34.1 L	9 gal	34.1 L	9 gal

Sound & Vibration Levels

Sound pressure level (ground workstation)	70 dBA (DC)	78 dBA (BI)	70 dBA (DC)	78 dBA (BI)
Sound pressure level (platform workstation)	70 dBA (DC)	76 dBA (BI)	70 dBA (DC)	76 dBA (BI)
Vibration	<2.5 m/s ²	<8 ft 2 in/s ²	<2.5 m/s ²	<8 ft 2 in/s ²

Weight****

CE DC foam filled tyres	6,963 kg	15,350 lbs	7,394 kg	16,300
CE Bi-Energy foam filled tyres	7,190 kg	15,850 lbs	7,620 kg	16,800

Standards Compliance EU Directives: 2006/42/EC - Machinery (harmonized standard EN280:2001+A2:2009); 2004/108/EC (EMC); 2006/95/EC (LVD); 2000/14/EC (Outdoor Noise)

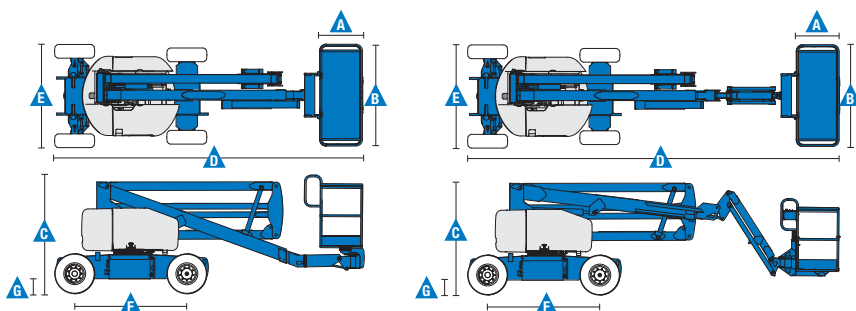

Range Of Motion Z-45/25

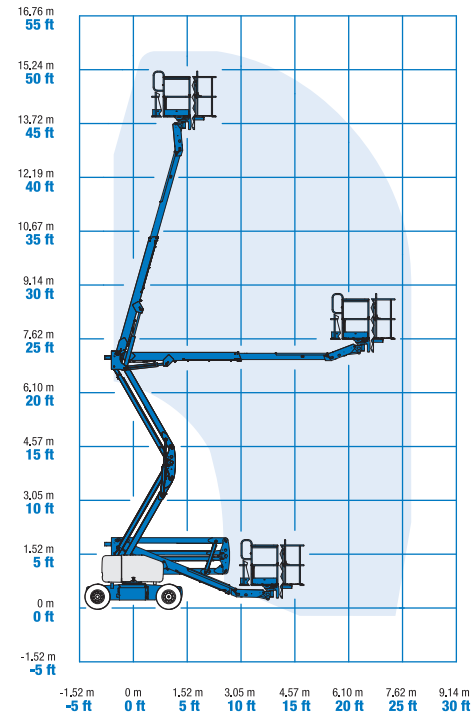

Range Of Motion Z-45/25J

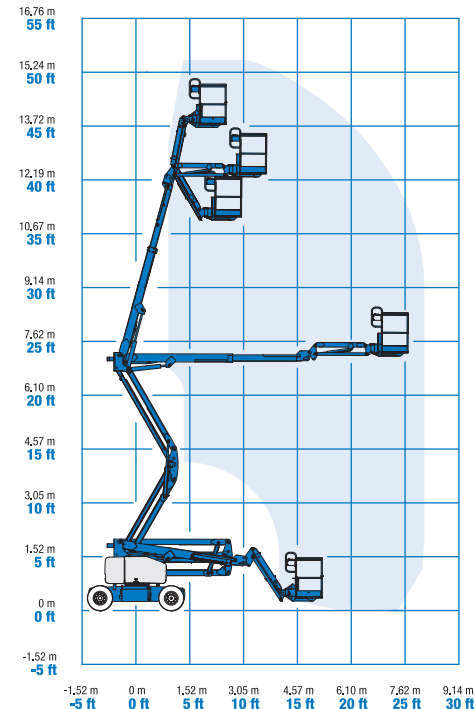

* The metric equivalent of working height adds 2 m to platform height. U.S. adds 6 ft to platform height.
 ** In lift mode (platform raised), the machine is designed to operate on firm, level surfaces only.
 *** Gradeability applies to driving on slopes. See operator's manual for details regarding slope ratings.
 **** Weight will vary depending on options and/or country standards.

Features

Standard Features	Easily Configured To Meet Your Needs	Options & Accessories
-------------------	--------------------------------------	-----------------------

Measurements

Z-45/25

- 15.87 m (51 ft 6 in) working height
- 7.62 m (25 ft) horizontal reach
- 7.04 m (23 ft 1 in) up and over clearance
- Up to 227 kg (500 lbs) lift capacity

Z-45/25J

- 15.94 m (51 ft 9 in) working height
- 7.65 m (25 ft 1 in) horizontal reach
- 7.04 m (23 ft 1 in) up and over clearance
- Up to 227 kg (500 lbs) lift capacity

Productivity

- Self-levelling platform
- Hydraulic platform rotation
- Proportional joystick controls
- Thumb rocker steer
- Drive enable
- AC power to platform
- Horn
- Hour meter
- Tilt alarm
- Descent & travel alarms
- Flashing beacon
- 355° non-continuous turntable rotation
- Zero tailswing
- Certified load sensor

Power

- 48V deep cycle battery pack
- 24V DC auxiliary power
- On board alternator powered by Tier IV Kubota 9.9 kW (13.3 hp) engine (Bi-energy model only)
- Universal 30A battery smart charger
- Battery charge indicator
- Low battery voltage interrupt

Platform Options

- Steel 1.83 m (6 ft) (standard)
- Steel 1.17 m (3 ft 10 in) (option)
- Steel 1.83 m (6 ft) tri-entry (option)

Jib Options

- Non-jib
- Articulating 1.52 m (5 ft) jib boom

Power

- 48V DC (eight 6V 350 Ah batteries)

Drive

- 2 x 4

Tyre Options

- Industrial foam-filled (standard)
- Industrial non-marking foam-filled

Productivity

- Platform top auxiliary rail
- Air line to platform
- Power to platform (incl. plug, socket and ground fault interrupt leakage on request)
- Work lights package (2 on chassis, 2 on platform)
- Biodegradable hydraulic oil ⁽¹⁾
- Hostile environment kit ⁽¹⁾: cylinder bellows, boom wiper seals and platform control box covers
- Aircraft protection kit ^(1,3): platform foam padding and padded disable system (available on Jib models only)
- Tilt cut-out option
- Track & Trace ⁽⁴⁾ (GPS unit providing machine location & operating information)
- Lockable platform control box cover
- Tool Tray
- Operator Protective Structure
- Operator Protective Alarm

Power

- AGM maintenance-free batteries ⁽¹⁾
- Diesel catalytic muffler ⁽¹⁾ (Bi-Energy only)
- Low temperature cut-out module
- Engine heater option (Bi-Energy only)
- Refinery kit with spark arrestor and electric or mechanical Chalwyn valve (Bi-Energy only)

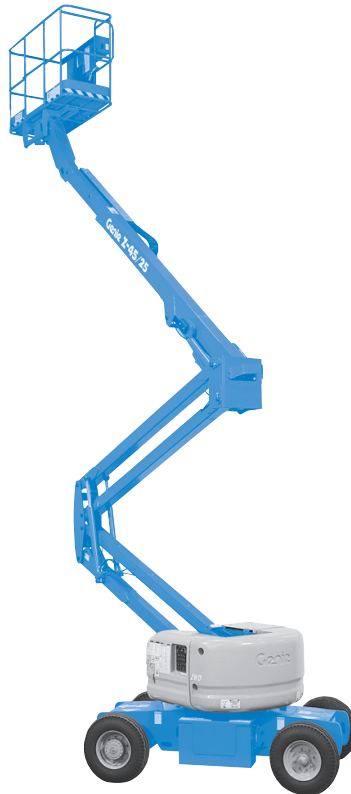

⁽¹⁾ Factory-fit option only
⁽²⁾ Not available on tri-entry platforms
⁽³⁾ Reduces platform load capacity to 440 lbs
⁽⁴⁾ Includes a first 2 years subscription

United Kingdom

The Maltings, Wharf Road, Grantham NG31 6BH, T: +44 800 988 3739 (toll free), Fax +44 (0)1476 584334, Email AWP-InfoEurope@terex.com
 Visit www.genielift.co.uk/locations to view our global locations list.

Worldwide Manufacturing And Distribution

Australia · Brazil · Caribbean · Central America · China · France · Germany · Italy · Japan · Korea · Mexico · Russia · Southeast Asia · Spain · Sweden · United Arab Emirates · United Kingdom · United States

Effective Date: February, 2014. Product specifications and prices are subject to change without notice or obligation. The photographs and/or drawings in this document are for illustrative purposes only. Refer to the appropriate Operator's Manual for instructions on the proper use of this equipment. Failure to follow the appropriate Operator's Manual when using our equipment or to otherwise act irresponsibly may result in serious injury or death. The only warranty applicable to our equipment is the standard written warranty applicable to the particular product and sale and we make no other warranty, express or implied. Products and services listed may be trademarks, service marks or trade names of Terex Corporation and/or their subsidiaries in the USA and many other countries. Genie is a registered trademark of Terex South Dakota, Inc. © 2014 Terex Corporation.

